

IT - ISTRUZIONI DI MONTAGGIO
EN - ASSEMBLY INSTRUCTIONS
DE - MONTAGEANLEITUNG
FR - INSTRUCTIONS DE MONTAGE

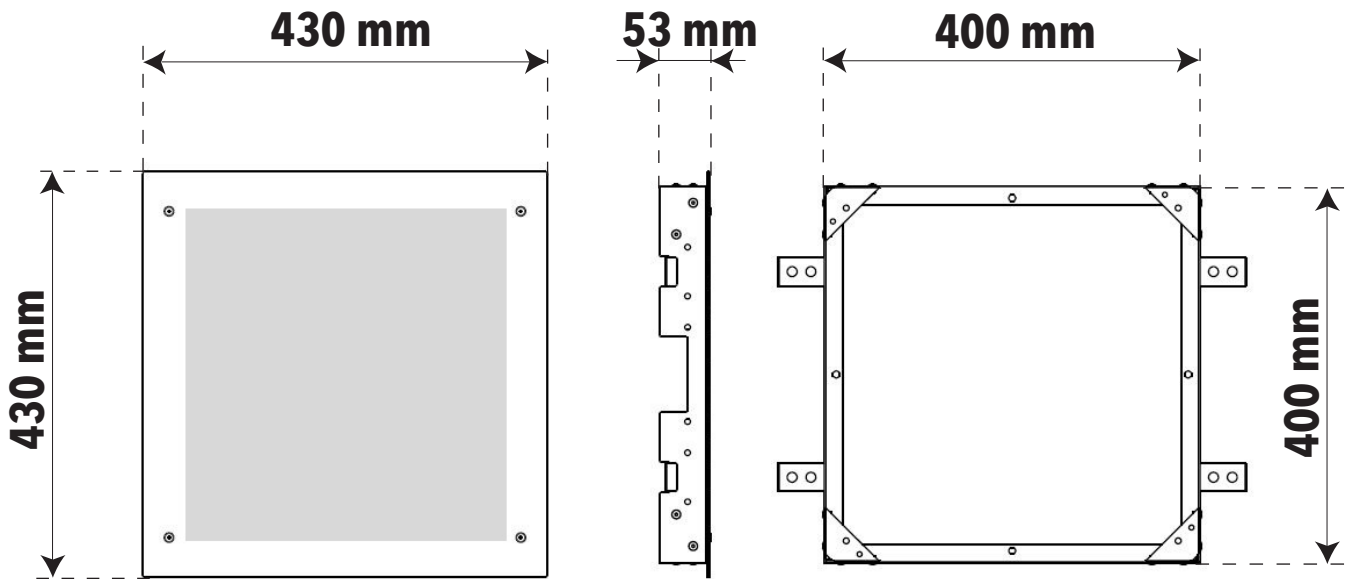

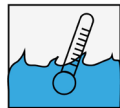

IT-Dimensioni sede telaio
 EN-Hole cut size
 DE-Rahmensitz Abmessungen
 FR-Dimensions du siège du cadre

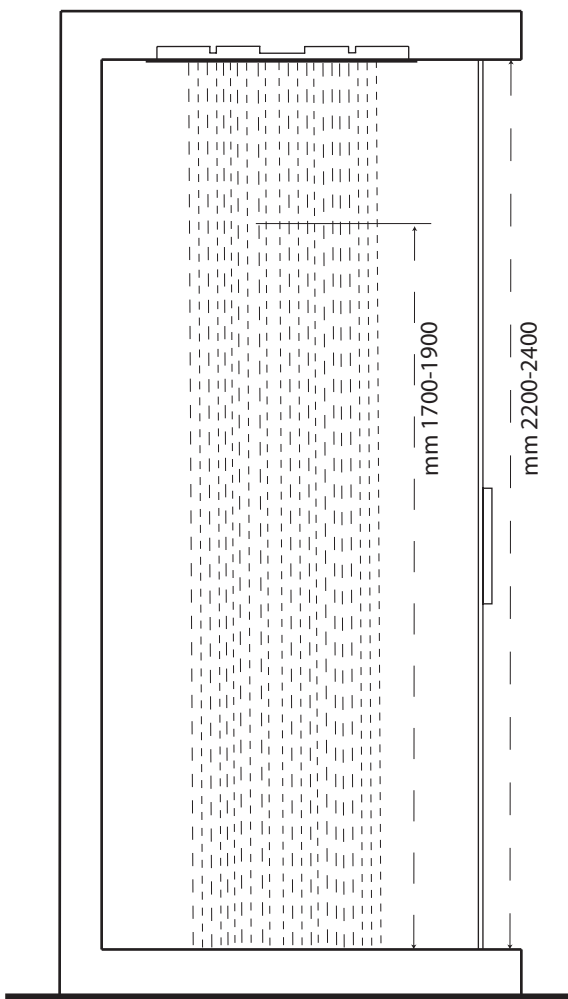

MAX 70°C
 BEST 38/40°C



MIN 1 Bar
 MAX 5 Bar
 BEST 3 Bar

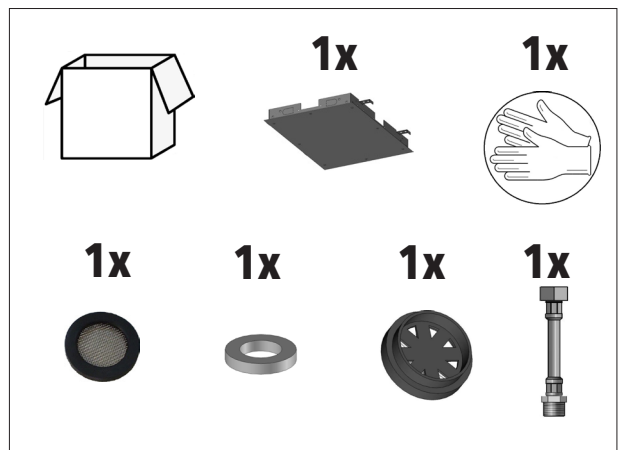
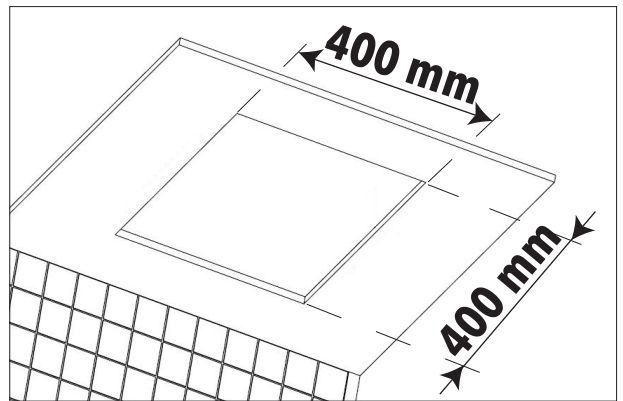

IT - L'apparechio deve essere installato da personale abilitato ai sensi e per l'effetto delle leggi in vigore.
 EN - According to the law, all installation and maintenance operations require a qualified person.
 DE - Das Gerät muss von qualifiziertem Personal gemäß den geltenden Gesetzen installiert werden.
 FR - L'appareil doit être installé par du personnel qualifié conformément et pour l'effet des lois en vigueur.

1

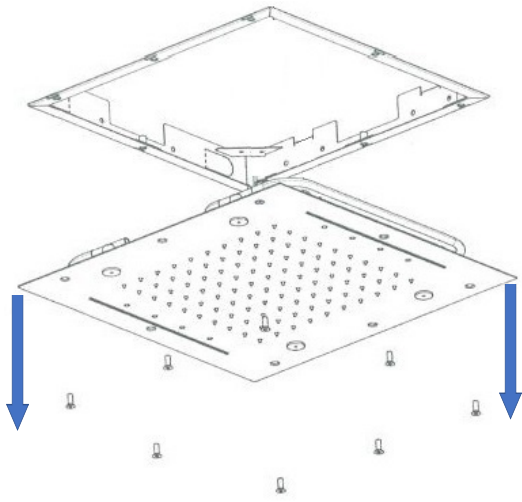

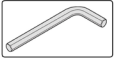
 Ch. 2 mm



3

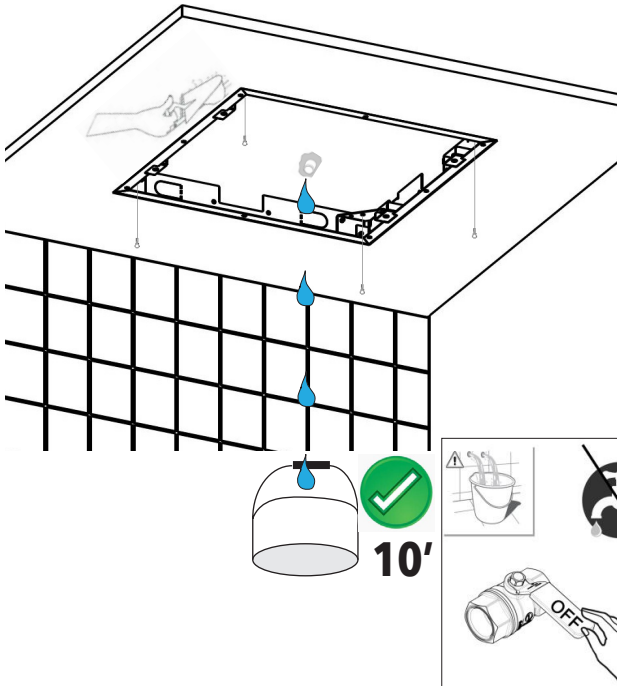

5

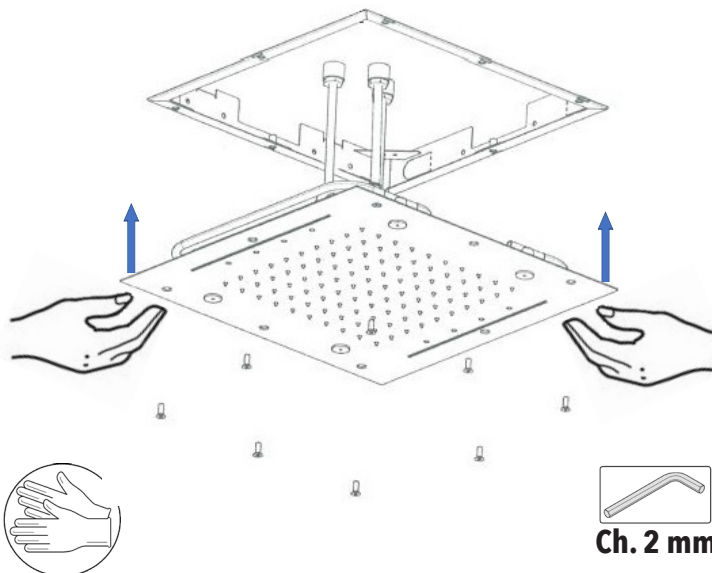

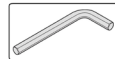
 Ch. 2 mm

2

IT-Usare per il fissaggio
 EN-Use clamps for fixing
 DE-Zum Befestigen verwenden
 FR-Utiliser pour la fixation

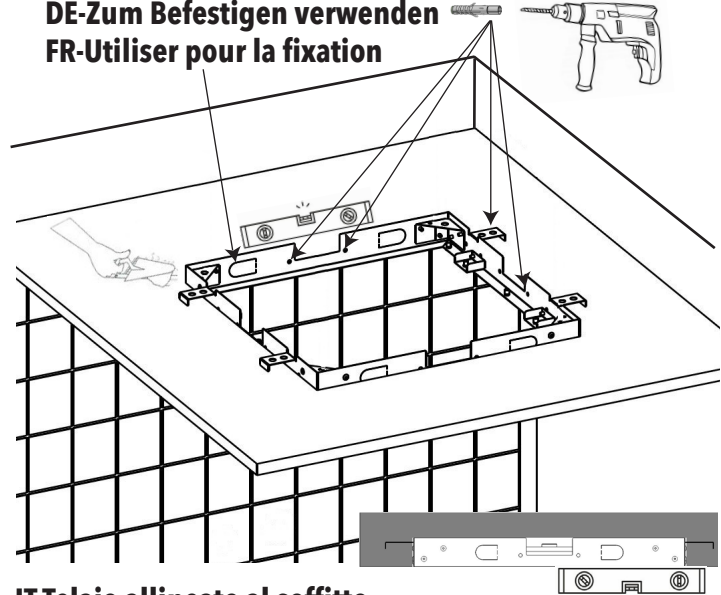

IT-Telaio allineato al soffitto
 EN-Align frame to ceiling
 DE-Rahmen aus der Decke ausgerichtet
 FR-Installez le cadre bien aligné au plafond



4

300 mm
 IT-Pioggia
 EN-Rain
 DE-Regen
 FR-Pluie

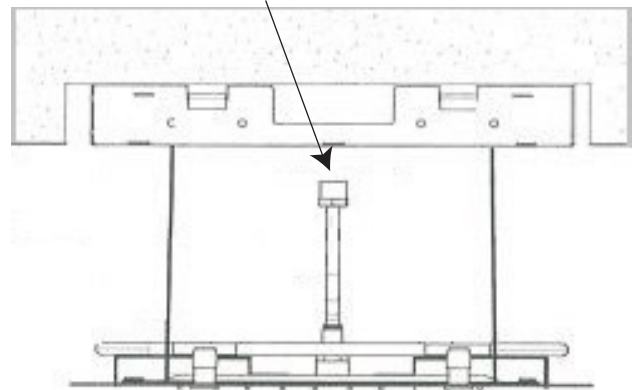



IT - LA GARANZIA DEL PRODOTTO NON COPRE

X L'utilizzo improprio.
L'errata predisposizione dell'impianto idraulico.
Danni causati da depositi di calcare o altre impurità.
Detergenti non adatti.

EN - NOT COVERED BY PRODUCT CARE

Not correct use.
Incorrect setup of the hydraulic system.
Water impurities or limestone deposits.
Improper detergents.

DE - DIE PRODUKTGARANTIE GILT NICHT

Die falsche Verwendung
Die falsche Anordnung des Hydrauliksystems.
Schäden durch Kalkablagerungen oder andere
Verunreinigungen.
Ungeeignete Reiniger.

FR - LA GARANTIE DU PRODUIT NE COUVRE PAS

Utilisation incorrecte.
La mauvaise disposition du système hydraulique.
Dommages causés par des dépôts de calcaire ou
d'autres impuretés.
Nettoyants inappropriés.

IT - DUE ANNI DI GARANZIA DEL PRODOTTO

✓ Contro i difetti o vizi di fabbricazione.

EN - TWO-YEAR PRODUCT CARE

Against defects of fabrication.

DE - ZWEI JAHRE LANG PRODUKTGARANTIE

Gegen Mängel oder Herstellungsfehler

FR - GARANTIE DE PRODUITS DE DEUX ANS

Contre les défauts de fabrication.

IT - ATTENZIONE: Si declina ogni responsabilità relativa ad eventuali inesattezze contenute in queste istruzioni dovute ad errori di trascrizione.

EN - WARNING: We decline all responsibility for eventual inaccuracy contained in the instructions due to transcript errors.

DE - ACHTUNG: Wir lehnen jede Verantwortung für Ungenauigkeiten in diesen Anleitung aufgrund von Transkriptionsfehlern ab.

FR - ATTENTION: Nous déclinons toute responsabilité pour toute inexactitude contenue dans ces instructions en raison d'erreurs de transcription.