

cisal

SLIM
Collection

design by Cisol Atelier



cisal



cisal

RAITAROV

«La bellezza del luogo ci illude, e a momenti ci fa credere che il tempo si sia fermato»

Orta mia. Mario Soldati 1960

“The beauty of this place deceives us, and at times makes us believe that time stands still”

Orta mia. Mario Soldati 1960



CHI SIAMO

CISAL rappresenta un esempio di industria italiana autonoma ed integrata, a ciclo di produzione completo, caratterizzato da soluzioni tecnologiche e gestionali innovative. Cisal è oggi uno dei protagonisti dell'innovazione nel settore, con grande sensibilità per l'efficiente uso delle risorse, in primis acqua ed energia, e costante attenzione allo sviluppo continuo di prodotti innovativi nel design, nei materiali, nel funzionamento e nelle prestazioni. Le Collezioni combinano sapientemente estetica, funzionalità e affidabilità, grazie alla collaborazione con designers internazionali quali Karim Rashid, Giampiero Peia, Fabio Rotella.

ABOUT US

Cisal is the outstanding example of an independent and fully integrated Italian manufacturer, performing the complete production cycle, characterised by innovative technology and management solutions. Cisal is now one of the leading innovators in the industry and is very conscience about the efficient use of resources, water and energy, and focuses on the continuous development of innovative products with regard to design, materials, function and performance. Thanks to collaboration with international designers such as Karim Rashid, Giampiero Peia, Fabio Rotella, the Collections masterfully combine aesthetics, functionality and reliability.



1952

Fondata nel 1952 da Liborio Soldi e battezzata CISAL, la società ha attraversato tutte le stagioni dell'epopea della rubinetteria di cui il Cusio è protagonista fin dagli albori.

Founded in 1952 by Liborio Soldi and named CISAL, the company has gone through all the epic seasons of brassware industry where Cusio has been the protagonist since the beginning.



1980

Nel 1980 l'Arch. Raffaella Vecchi disegna la serie ARCANA, un prodotto icona classico e storico che apre nuovi orizzonti nei mercati esteri, che si sviluppano passando anche attraverso la creazione di una filiale in Germania nel 1991.

In 1980 the Architect Raffaella Vecchi, designed the ARCANA series, a classical and historical icon that opens up new horizons in foreign markets, which also led to the establishment of a daughter company in Germany in 1991.



1981

Dal lavoro di sviluppo interno coordinato da Daniele Sirini, nasce la prima cartuccia a dischi ceramici monocomando. Il nuovo BLITZ apre la gloriosa storia delle serie di miscelazione Cisal.

The first single handle ceramic disc cartridge was developed internally by Daniele Sirini and his team. The glorious history of Cisal mixer series begins with the new BLITZ series.



1999

Nel 1999, viene realizzato un nuovo stabilimento disegnato dall'Arch. Giampiero Peia e attrezzato con modernissimi impianti di cogenerazione, galvanica e magazzino elettronico. Qui si concentrano le tecnologie più avanzate del settore e si supporta una crescita continua nella progettazione del prodotto, nell'ingegnerizzazione del manufatto e del prodotto finito.

In 1999, a new factory building designed by the architect Giampiero Peia was built and equipped with modern cogeneration and plating plants along with an electronic warehouse. Here, using the most advanced technologies in the industry, product design and the engineering of the part and the finished product are in continuous development.



2009

Nel 2009 la famiglia Huber, proprietaria di Huber, leader nella fabbricazione di miscelatori termostatici, decide di fare una scelta strategica per il futuro, acquisendo Cisal per garantirle un asse di sviluppo tecnologico e industriale assolutamente vincente: combinare know-how, esperienza e capacità produttive per offrire al progettista e alla clientela una variegata e completa gamma di prodotti integrati a miscelazione termostatica, monocomando e tradizionale.

In 2009 the Huber family, owner of Huber, a leading manufacturer of thermostatic mixers, decided to make a strategic choice for the future, by acquiring Cisal and providing the company with an absolutely successful technological and industrial development format: to combine know-how, experience and production capacities in order to offer designers and customers a wide and complete range of single lever, traditional, and thermostatic brassware products.



2016

Nel 2016 l'Architetto Fabio Rotella entra a far parte del team dell'azienda e in qualità di art director ha ideato "CISALAtelier", centro creativo che, attraverso la ricerca e la sperimentazione, lavora su progetti di prodotti sempre più protagonisti, grazie ad un autentico appeal.

Architect Fabio Rotella joining the team in 2016 as the brand art director, he developed the "CISALAtelier" concept, a creative network which, through research and experimentation, will be protagonist on projects of key products thanks to their authentic appeal.



ECCELLENZA MADE IN ITALY

Cisal rappresenta un capitolo importante della storia della rubinetteria italiana. Una lunga tradizione di ingegno, mestiere e professionalità, declinata ed esaltata nel rispetto e nella considerazione per l'uomo ed il territorio: il Lago d'Orta, luogo in cui si concentra da generazioni il distretto della rubinetteria, retaggio di artigianalità e cultura del saper fare italiano.

MADE IN ITALY EXCELLENCE

Cisal represents an important chapter in the history of Italian brassware. A long tradition of ingenuity, skill and professionalism, identified and enhanced in respect and consideration for humans and the territory: Lake Orta, the area where taps have been made for generations, has a heritage of craftsmanship and a culture of Italian know-how.



cisal Atelier CONCEPT

L'acqua è l'elemento essenziale per l'essere umano e il suo controllo è importante sin dall'antichità. Il rubinetto, dispensatore del liquido vitale del quale facciamo un utilizzo quotidiano, è un prodotto funzionale e necessario ma può anche rappresentare un accessorio sofisticato, prezioso e sempre più protagonista nell'ambiente bagno. Cisal storicamente ha da sempre caratterizzato la sua vasta gamma di collezioni con un atteggiamento di ricerca formale riferito al design. Più recentemente, con l'integrazione delle competenze della famiglia Huber, Cisal si è ulteriormente elevata ad ancora più alti livelli di qualità e prestigio, affermandosi come un importante interprete del settore bagno e cucina a livello internazionale.

Nel 2016 l'Architetto Fabio Rotella entra a far parte del team dell'azienda e in qualità di art director ha ideato "CISALAtelier", centro creativo che, attraverso la ricerca e la sperimentazione, lavora su progetti di prodotti sempre più protagonisti, grazie ad un autentico appeal.

"In questi anni di grandi cambiamenti, in un contesto internazionale sempre più sofisticato e in continua evoluzione, Cisal, nella sua nuova visione strategica, intende sviluppare ed elevare la propria immagine rendendola unica e riconoscibile, e aumentare la percezione dei suoi prodotti e delle sue innovazioni sullo scenario globale. Nuovi materiali, nuove finiture, nuovi dettagli e nuove tecnologie per controllare e preservare l'acqua. Cisal si presenta come un'azienda Italiana di tradizione e all'avanguardia, proiettata verso il futuro e sempre più attenta alle attese di designers e utilizzatori e alla salvaguardia dell'elemento essenziale per il Pianeta: l'acqua."

Fabio Rotella

Water is the essential element for the human being - and controlling it has been important since ancient times.

The tap, dispenser of this vital liquid of which we use daily, is a functional and necessary product, but it can also be a sophisticated, precious accessory as well that plays an increasingly important role in the bathroom environment. Since its origin, Cisal's wide range of collections have always been characterized by formal research related to design. Recently, with the integration of the expertise of the Huber family, Cisal has elevated its already high levels of quality and prestige even further, establishing itself internationally as a major interpreter of the bathroom and kitchen industry.

Architect Fabio Rotella joining the team in 2016 as the brand art director, he developed the "CISALAtelier" concept, a creative network which, through research and experimentation, will be used on projects of key products thanks to their authentic appeal.

"During these years of great change, in an international context that is becoming more sophisticated and is constantly evolving, Cisal, with its new strategic vision, aims to develop and enhance its image, making it unique and recognizable, and to globally increase the perception of its products and innovations. New materials, new finishes, new details and new technologies to control and preserve water. Cisal is a cutting-edge, future-oriented Italian company that is rich in tradition and is increasingly aware of the expectations of designers and users, and the preservation of the essential element of our planet: water."

Fabio Rotella



WATER CREATIVITY



SLIM Collection

design by Cital Atelier

Smart,
riconoscibile e
particolari
contemporanei

*Smart,
recognizable and
contemporary
details*

SLIM



18

SM 106
Batteria Lavabo
Basin Set



19

SLIM



20

SM 106
Batteria Lavabo
Basin Set



21



22



SM 1351
Batteria Lavabo
Basin Set



SM 102
Batteria Lavabo
Basin Set

23



SM 171
Monocomando Lavabo Progressivo
Progressive Basin Mixer



SM 71
Monocomando Lavabo Progressivo
Progressive Basin Mixer



SM 155
Monocomando Bidet Progressivo
Progressive Bidet Mixer

SLIM



26

SM 420
Completo Monocomando Vasca Free-Standing
Free-Standing Bath/S. Mixer Set



27

SLIM



28

SM D2301
Completo Termostatico Vasca
Thermo Bath/S. Set



SM 1810
Termostatico 2 Uscite
2-Outlet Thermo



SM 210
Monocomando 2 Uscite
2-Outlet Mixer



DS 1881
Completo Doccia con Presa d'Acqua
Shower Set on Wall Elbow



DS 1072
Completo Doccia Saliscendi
Slide Rail Shower Set

29



30



SM C7801
CombiDoccia Termostatico
Thermo CombiShower

31

SLIM



32

SM 403
CombiDoccia Monocomando
CombiShower Mixer



SLIM



34

SM 1V20
Termostatico 2 Funzioni
2-Function Thermo



35



36

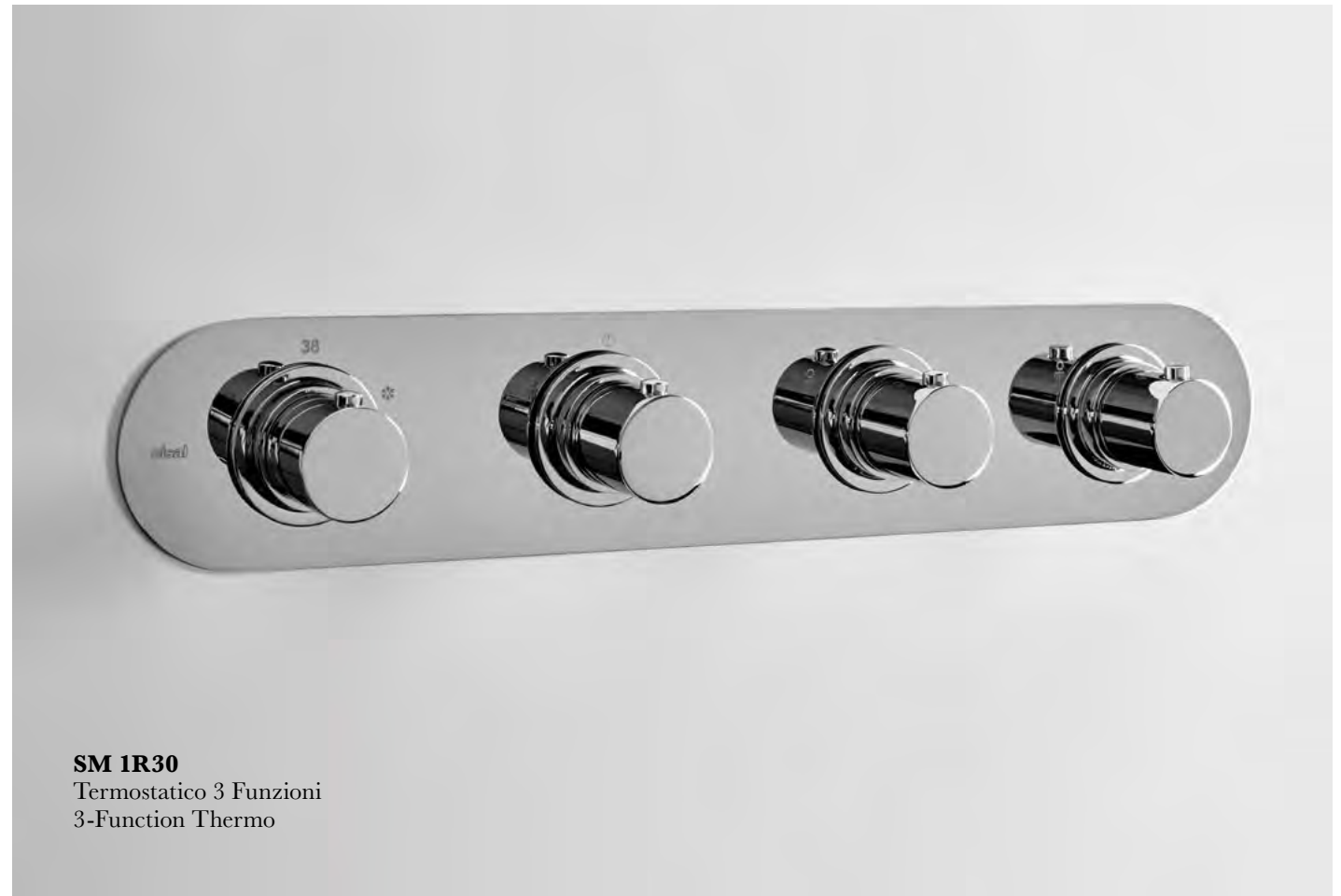

SM 1R30
Termostatico 3 Funzioni
3-Function Thermo

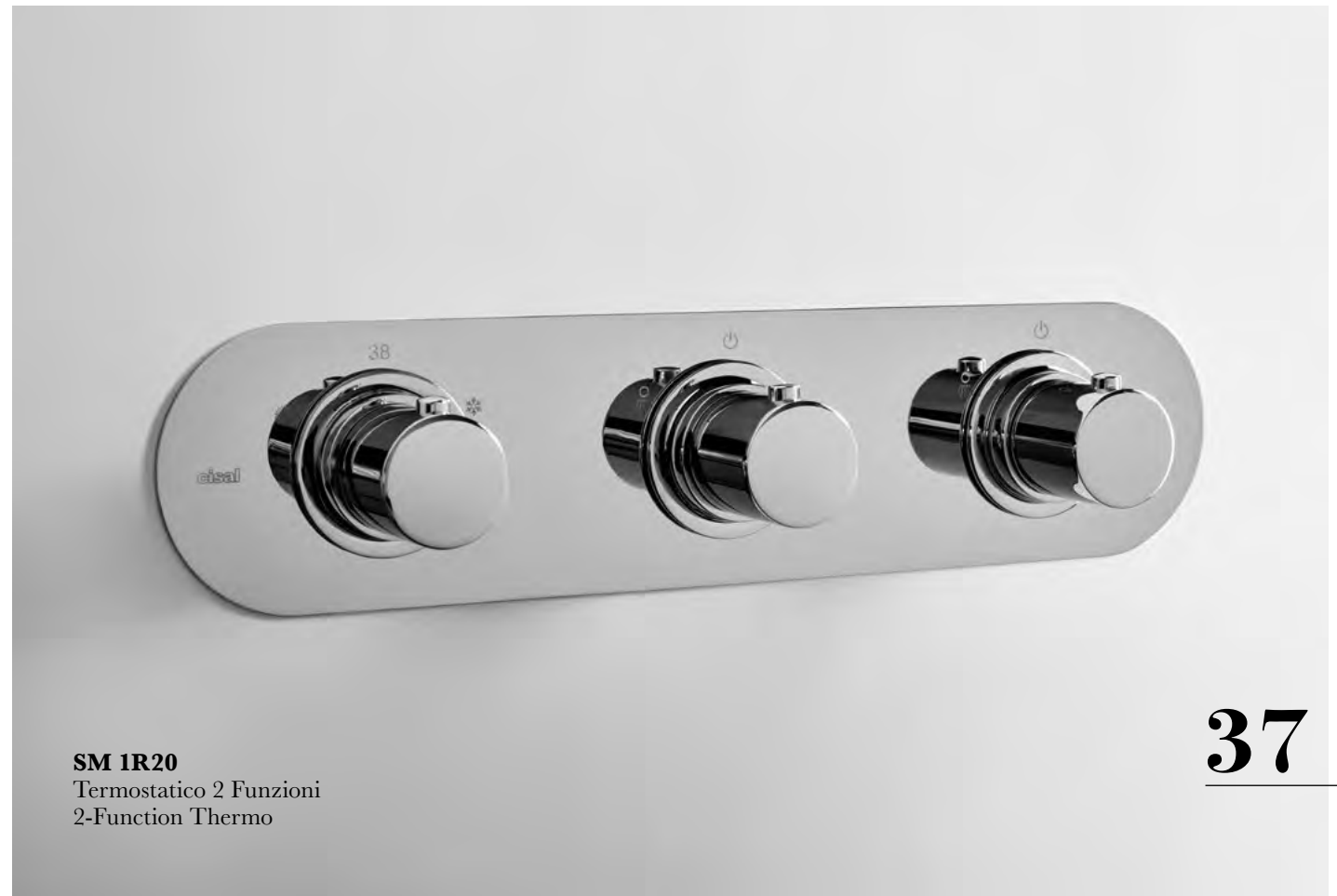

SM 1R20
Termostatico 2 Funzioni
2-Function Thermo

37

SLIM



38

SY 9091
Porta Salviette
Free-Standing Towel Rail



SY 9010 0 - SY 9010 1 - SY 9010 2
Porta Salviette
Towel Rail



SY 9065
Porta Scopino
Brush Holder



SY 9070
Appendino Multiplo
Multiple Hook

39



Prodotti e Accessori
Products and Accessories
Produits et Accessoires

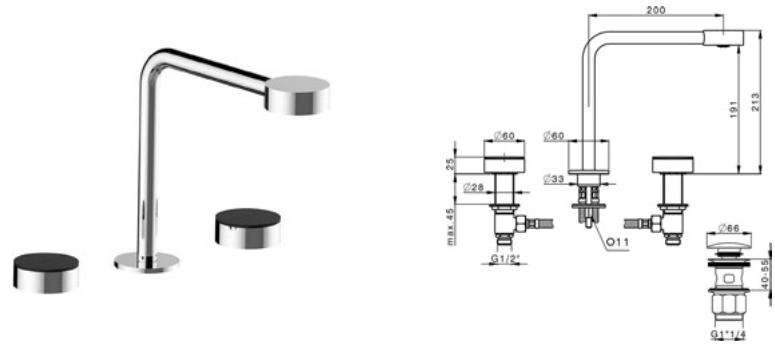

SM 001060
Batteria Lavabo
Basin Set
Lavabo 3 Trou

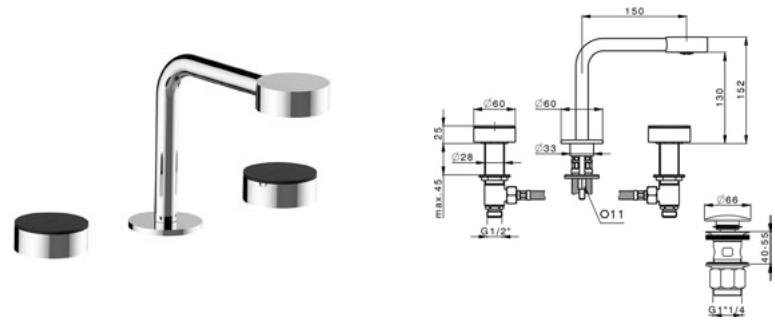

SM 001020
Batteria Lavabo
Basin Set
Lavabo 3 Trou

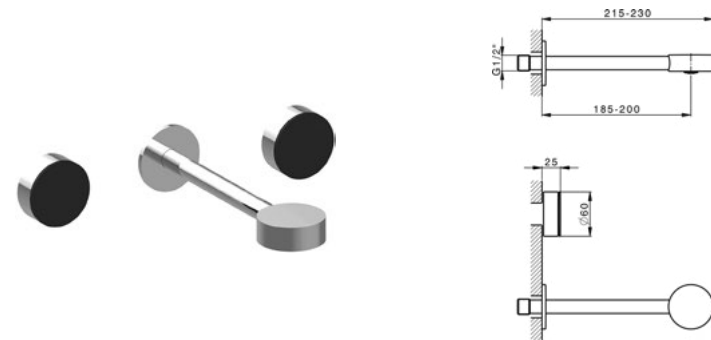

SM 013510
Parte Esterna Batteria Lavabo
Basin Set Exposed Part
Partie Apparente Lavabo Mural



ZA 033510
Parte Incasso Batteria Lavabo
Basin Set Concealed Part
Partie Encastrée Lavabo Mural



SM 000710
Monocomando Lavabo Progressivo
Progressive Basin Mixer
Mitigeur Lavabo Progressif



SM 000730
Monocomando Lavabo Progressivo
Progressive Basin Mixer
Mitigeur Lavabo Progressif



SM 001710
Monocomando Lavabo Progressivo
Progressive Basin Mixer
Mitigeur Lavabo Progressif



SM 001730
Monocomando Lavabo Progressivo
Progressive Basin Mixer
Mitigeur Lavabo Progressif

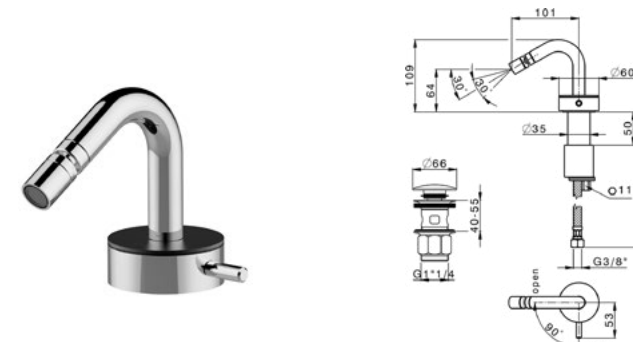

SM 001550
Monocomando Bidet Progressivo
Progressive Bidet Mixer
Mitigeur Lavabo Progressif



SM 001560
Monocomando Bidet Progressivo
Progressive Bidet Mixer
Mitigeur Lavabo Progressif

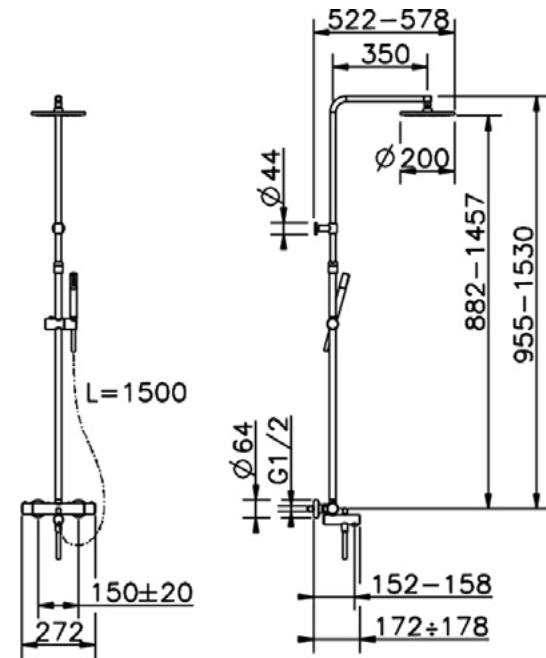

SM C85010
CombiVasca Termostatico
Thermo CombiBath
CombiBain Thermo

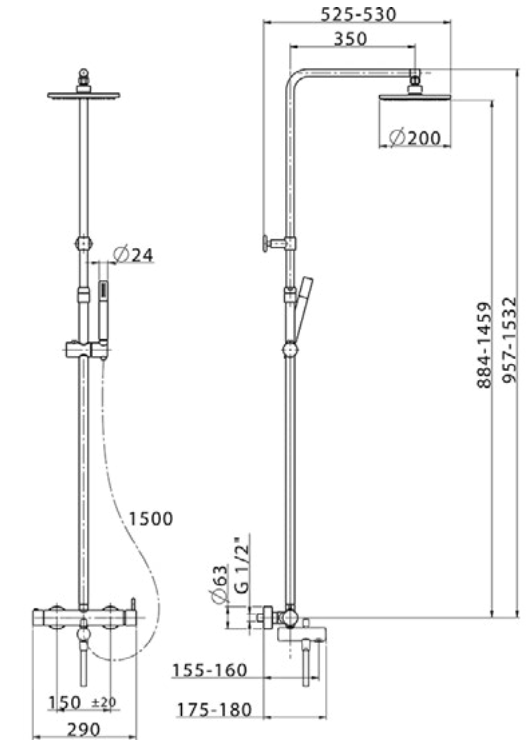

SM 004120
CombiVasca Monocomando
CombiBath Mixer
CombiBain Mitigeur

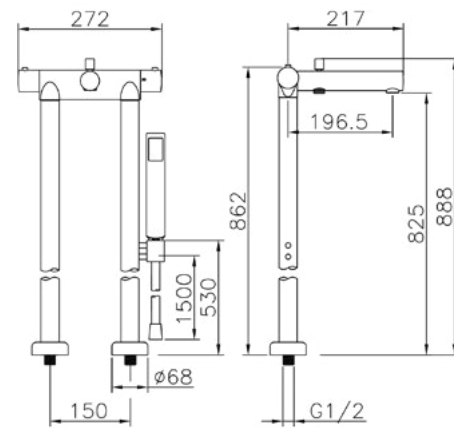

SM T39010
Completo Termostatico Vasca Free-Standing
Free-Standing Bath/S. Thermo Set
Ensemble Thermo Bain/D. Free-Standing

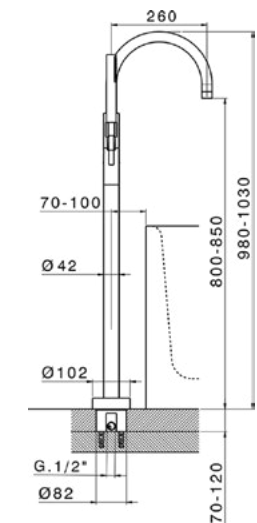

SM 004200
Completo Monocomando Vasca Free-Standing
Free-Standing Bath/S. Mixer Set
Ensemble Mitigeur Bain/D. Free-Standing

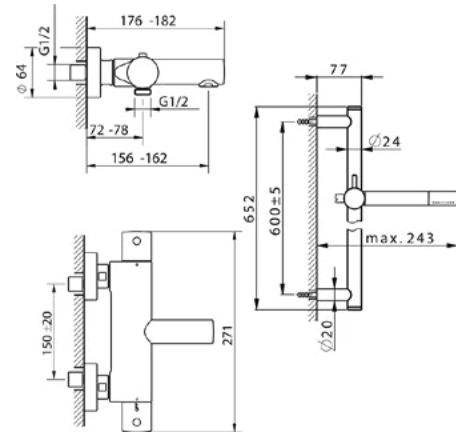

SM S23010
Completo Termostatico Vasca
Thermo Bath/S. Set
Ensemble Thermo Bain/D.

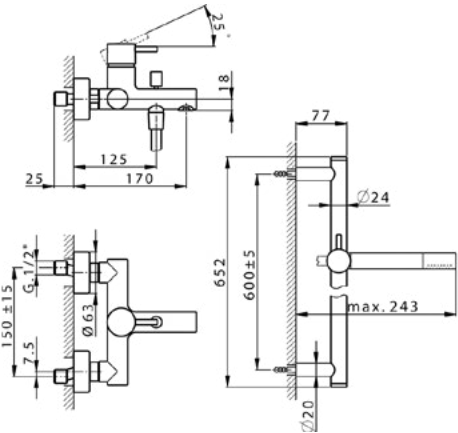

SM 000060
Completo Monocomando Vasca
Bath/S. Mixer Set
Ensemble Mitigeur Bain/D.

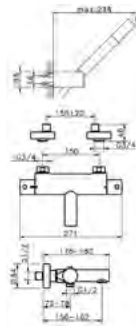

SM D23010
Completo Termostatico Vasca
Thermo Bath/S. Set
Ensemble Thermo Bain/D.

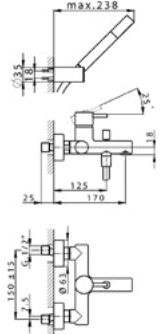

SM 000120
Completo Monocomando Vasca
Bath/S. Mixer Set
Ensemble Mitigeur Bain/D.

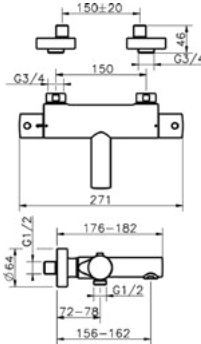

SM T23010
Termostatico Vasca
Bath/S. Thermo
Thermo Bain/D.

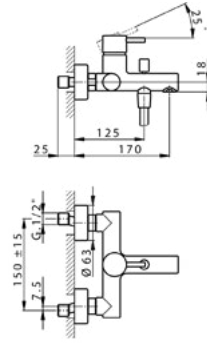

SM 000130
Monocomando Vasca
Bath/S. Mixer
Mitigeur Bain/D.

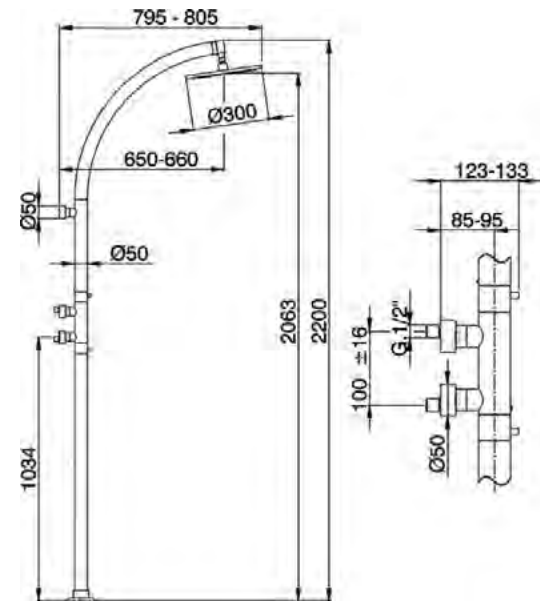

SM C90010
 Colonna Doccia Termostatica
 Thermo Shower Column
 Colonne de Douche Thermo

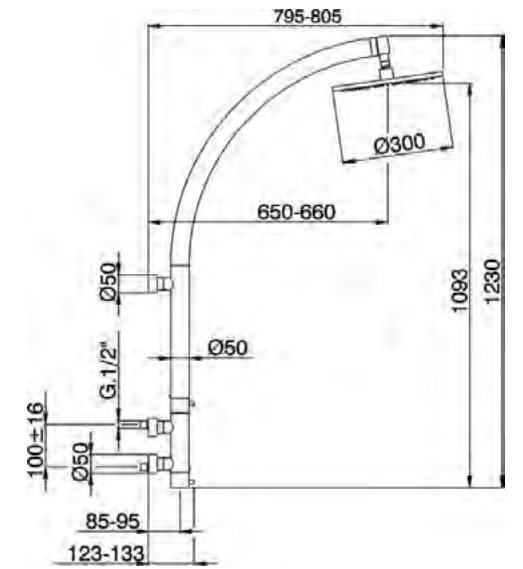

SM C91010
 Colonna Doccia Termostatica
 Thermo Shower Column
 Colonne de Douche Thermo

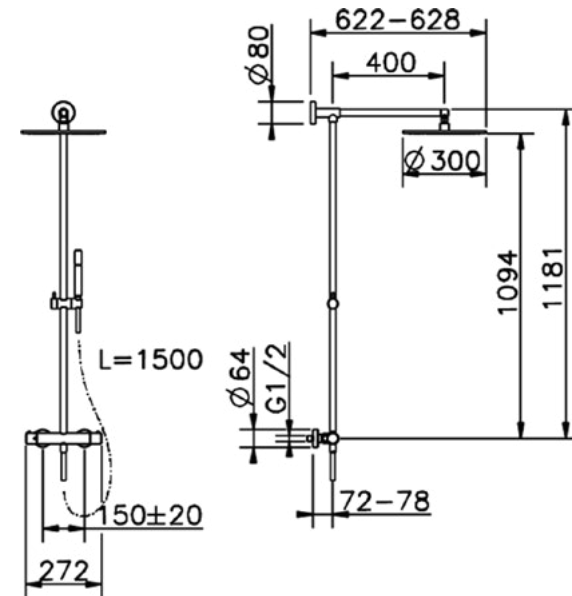

SM C78010
 CombiDoccia Termostatico
 Thermo CombiShower
 CombiDouche Thermo

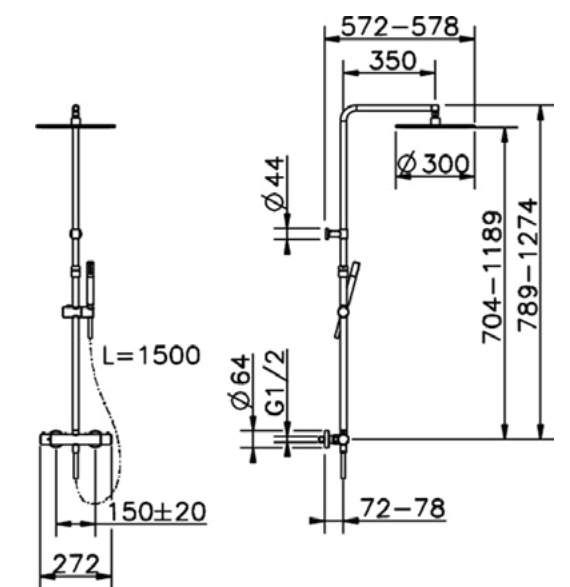

SM C84010
 CombiDoccia Termostatico
 Thermo CombiShower
 CombiDouche Thermo

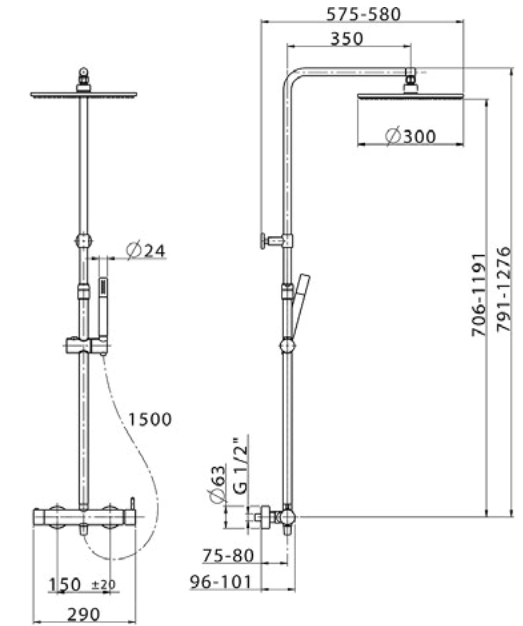

SM 004030
CombiDoccia Monocomando
CombiShower Mixer
CombiDouche Mitigeur

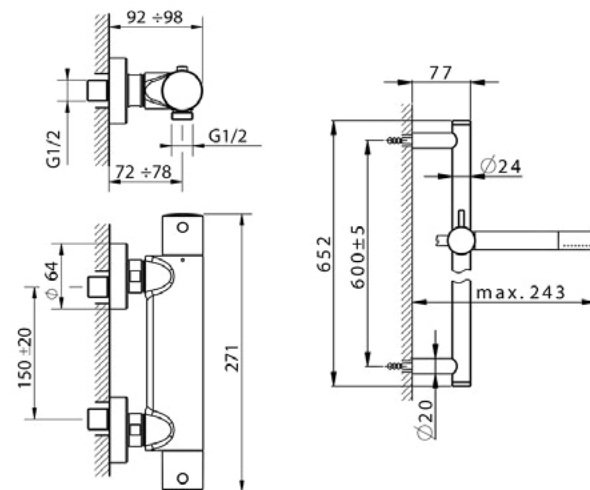

SM S01010
Completo Termostatico Doccia
Thermo Shower Set
Ensemble Thermo Douche

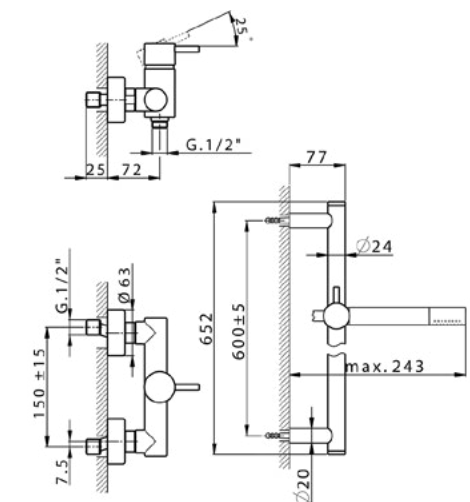

SM 000460
Completo Monocomando Doccia
Shower Mixer Set
Ensemble Mitigeur Douche

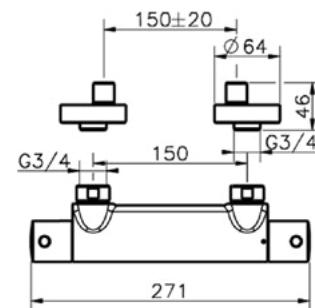

SM T01010
Termostatico Doccia
Shower Thermo
Thermo Douche

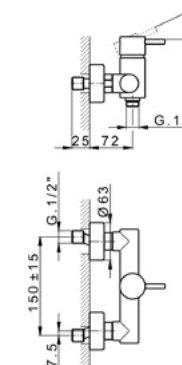

SM 000440
Monocomando Doccia
Shower Mixer
Mitigeur Douche

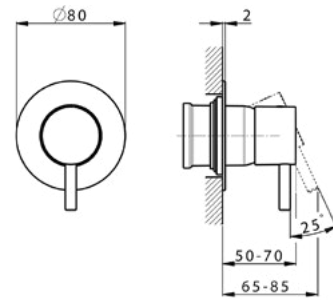

SM 003000
 Parte Esterna Monocomando Doccia
 Shower Mixer Exposed Part
 Partie Décor Mitigeur Douche

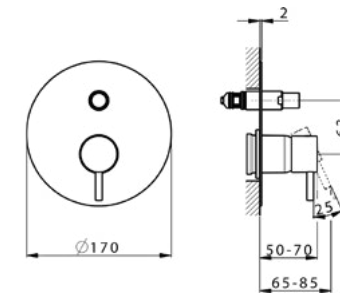
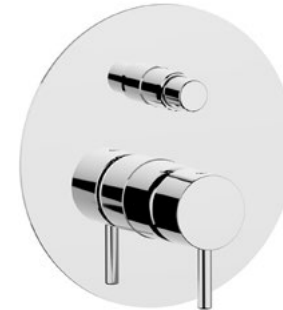

SM 002100
 Parte Esterna Monocomando 2 Uscite
 2-Outlet Mixer Exposed Part
 Partie Décor Mitigeur 2 Sorties

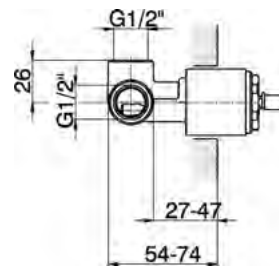

ZA 005300
 Parte Incasso Monocomando Doccia
 Shower Mixer Concealed Part
 Partie Encastrée Mitigeur Douche

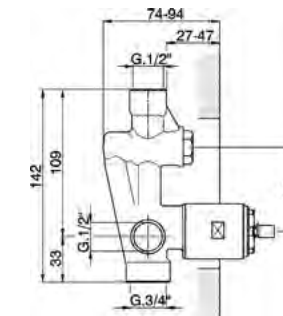

ZA 005210
 Parte Incasso Monocomando 2 Uscite
 2-Outlet Mixer Concealed Part
 Partie Encastrée Mitigeur 2 Sorties

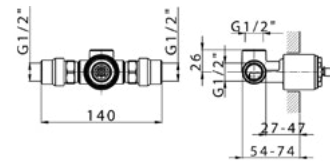

ZA 005301
 Parte Incasso Monocomando Doccia
 con Silenziatori
 Shower Mixer Concealed Part
 with Noise Reducers
 Partie Encastrée Mitigeur Douche
 avec Silencieux

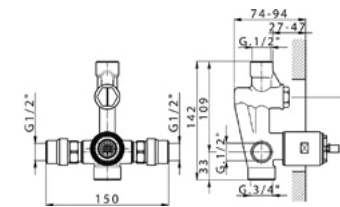

ZA 005211
 Parte Incasso Monocomando 2 Uscite
 con Silenziatori
 2-Outlet Mixer Concealed Part
 with Noise Reducers
 Partie Encastrée Mitigeur 2 Sorties
 avec Silencieux

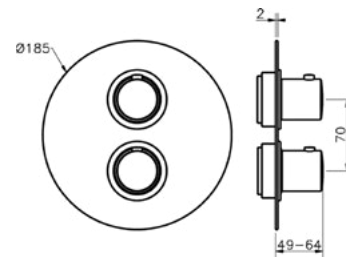

SM 007300
 Parte Esterna Termostatico Doccia
 Thermo Shower Exposed Part
 Partie Décor Thermo Douche

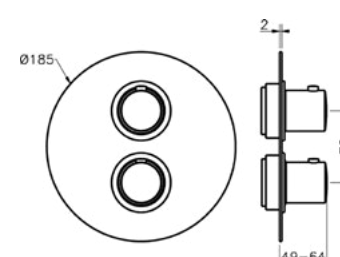

SM 018100
 Parte Esterna Termostatico 2 Uscite
 2-Outlet Thermo Exposed Part
 Partie Décor Thermo 2 Sorties

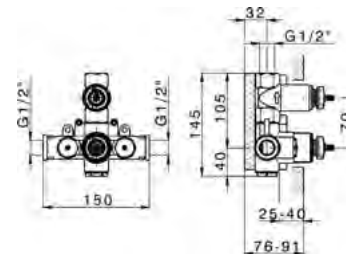

ZA 007301
 Parte Incasso Termostatico Doccia
 Thermo Shower Concealed Part
 Partie Encastrée Thermo Douche

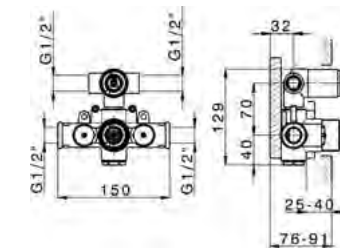

ZA 018101
 Parte Incasso Termostatico 2 Uscite
 2-Outlet Thermo Concealed Part
 Partie Encastrée Thermo 2 Sorties

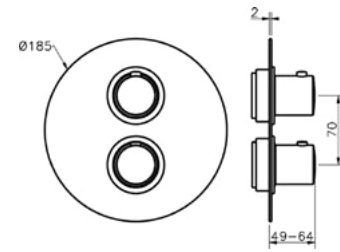

SM 018200
 Parte Esterna Termostatico 3 Uscite
 3-Outlet Thermo Exposed Part
 Partie Décor Thermo 3 Sorties

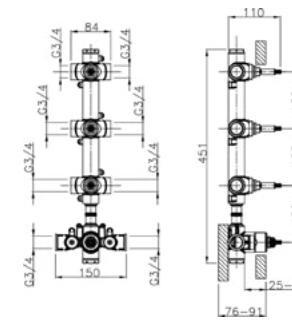

ZA 01V300
 Parte Incasso Termostatico 3 Funzioni
 3-Function Thermo Concealed Part
 Partie Encastrée Thermo 3 Fonctions

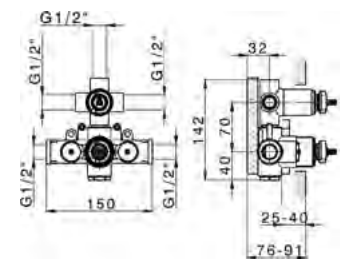

ZA 018201
 Parte Incasso Termostatico 3 Uscite
 3-Outlet Thermo Concealed Part
 Partie Encastrée Thermo 3 Sorties

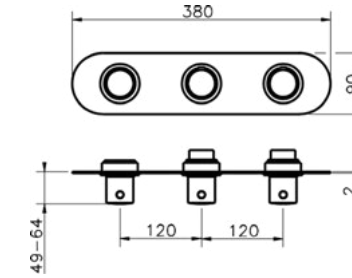

SM 01R200
 Parte Esterna Termostatico 2 Funzioni
 2-Function Thermo Exposed Part
 Partie Décor Thermo 2 Fonctions

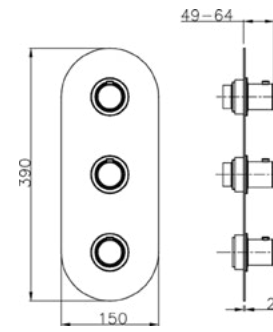

SM 01V200
 Parte Esterna Termostatico 2 Funzioni
 2-Function Thermo Exposed Part
 Partie Décor Thermo 2 Fonctions

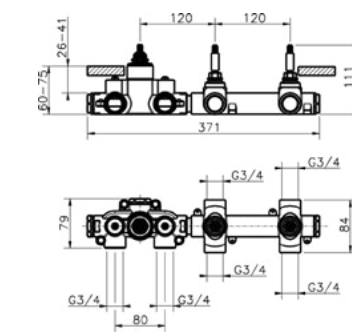

ZA 01R200
 Parte Incasso Termostatico 2 Funzioni
 2-Function Thermo Concealed Part
 Partie Encastrée Thermo 2 Fonctions

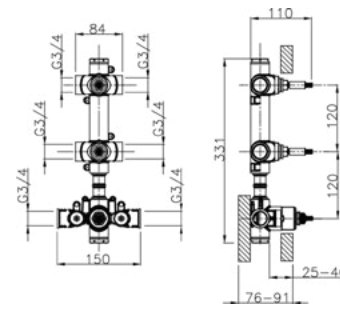

ZA 01V200
 Parte Incasso Termostatico 2 Funzioni
 2-Function Thermo Concealed Part
 Partie Encastrée Thermo 2 Fonctions

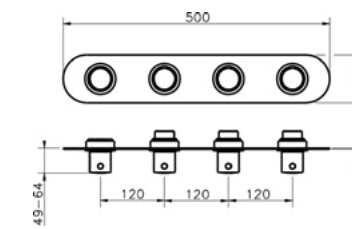

SM 01R300
 Parte Esterna Termostatico 3 Funzioni
 3-Function Thermo Exposed Part
 Partie Décor Thermo 3 Fonctions

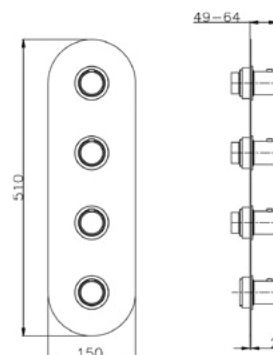

SM 01V300
 Parte Esterna Termostatico 3 Funzioni
 3-Function Thermo Exposed Part
 Partie Décor Thermo 3 Fonctions

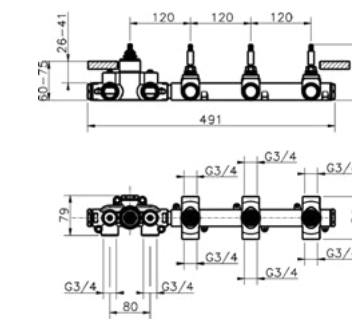

ZA 01R300
 Parte Incasso Termostatico 3 Funzioni
 3-Function Thermo Concealed Part
 Partie Encastrée Thermo 3 Fonctions

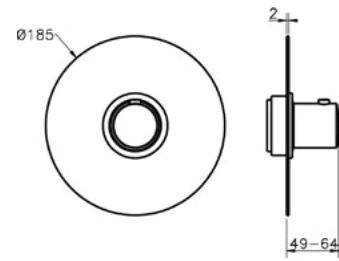

SM 007200
 Parte Esterna Termostatico 3/4"
 3/4" Thermo Exposed Part
 Partie Décor Thermo 3/4"

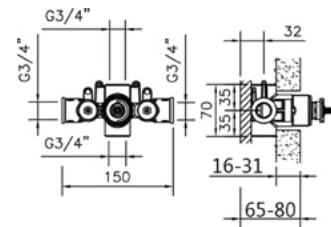

ZA 007220
 Parte Incasso Termostatico 3/4"
 3/4" Thermo Concealed Part
 Partie Encastrée Thermo 3/4"

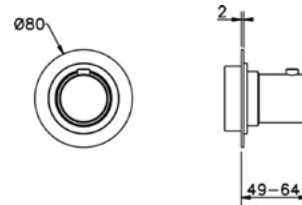

SM 003310
 Parte Esterna Rubinetto
 Stopvalve Exposed Part
 Partie Décor Robinet

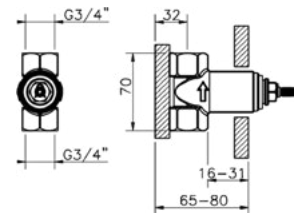

ZA 003330
 Parte Incasso Rubinetto 3/4"
 3/4" Stopvalve Concealed Part
 Partie Encastrée Robinet 3/4"

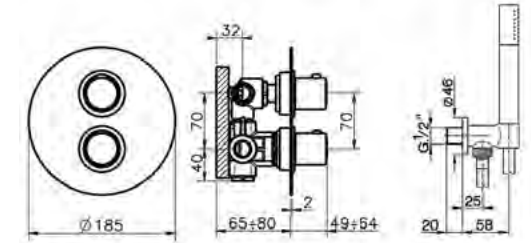
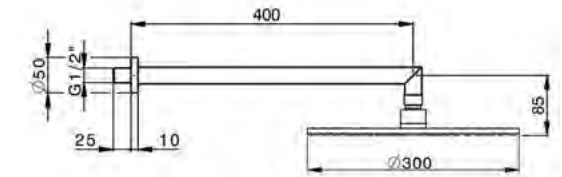

SM 0KT010
 Completo Termostatico Doccia 2 Funzioni
 2-Function Thermo Shower Set
 Ensemble Thermo Douche 2 Fonctions

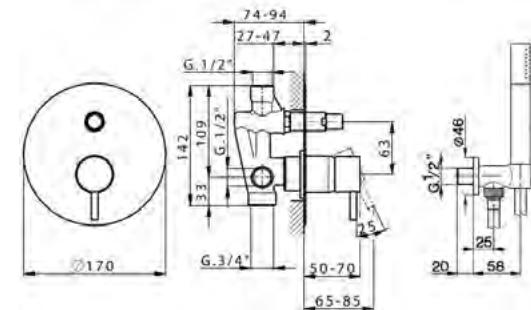
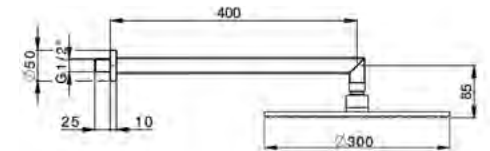

SM 0KM010
 Completo Monocomando Doccia 2 Funzioni
 2-Function Mixer Shower Set
 Ensemble Mitigeur Douche 2 Fonctions

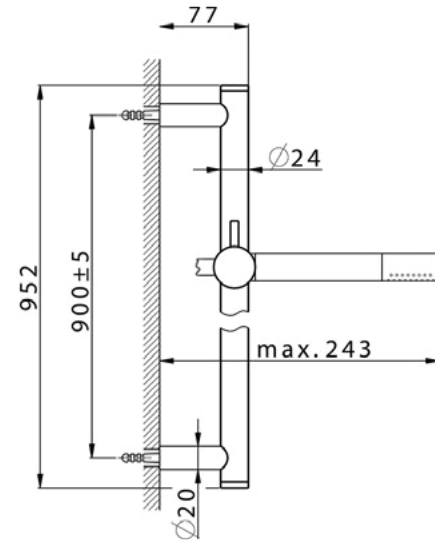

DS 010720
Completo Doccia Saliscendi 90 cm
90 cm Slide Rail Shower Set
Ensemble Barre de Douche 90 cm

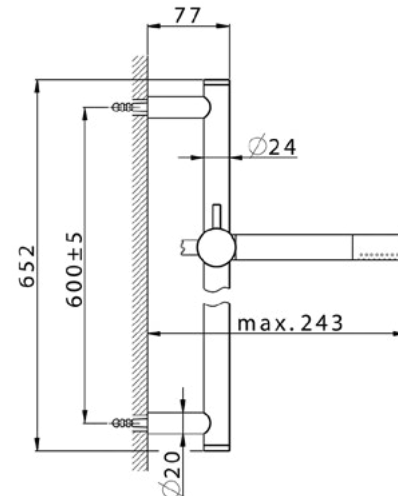

DS 010721
Completo Doccia Saliscendi 60 cm
60 cm Slide Rail Shower Set
Ensemble Barre de Douche 60 cm

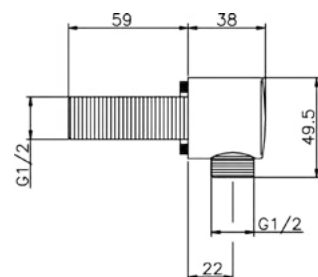

DS 017320
Presa d'Acqua
Wall Elbow
Coude Mural

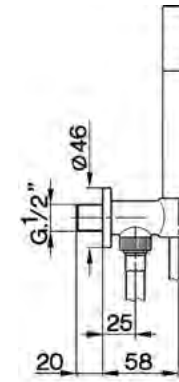

DS 018813
Completo Doccia con Presa d'Acqua
Shower Set on Wall Elbow
Ensemble de Douche sur Coude Mural

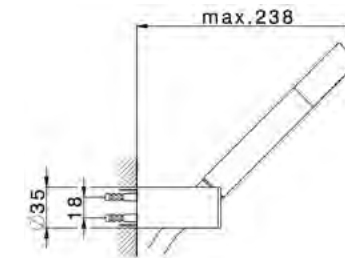

DS 018360
Completo Doccia
Shower Set
Ensemble de Douche

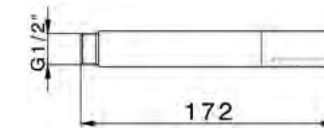

DS 014090
Doccetta
Hand Shower
Douchette à Main

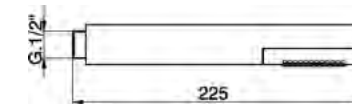

DS 014230
Doccetta
Hand Shower
Douchette à Main

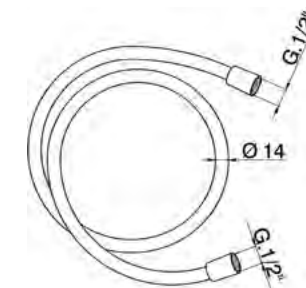

ZA 009040
Flessibile Doccia SUPREME
SUPREME Shower Hose
Flexible de Douche SUPREME



DS 013610
Braccio e Soffione Doccia
Shower Arm & Head
Bras et Tête de Douche



DS 016370
Soffione Doccia
Shower Head
Douche de Tête



DS 013620
Braccio e Soffione Doccia
Shower Arm & Head
Bras et Tête de Douche



DS 016330
Soffione Doccia
Shower Head
Douche de Tête



DS 013630
Braccio e Soffione Doccia
Shower Arm & Head
Bras et Tête de Douche

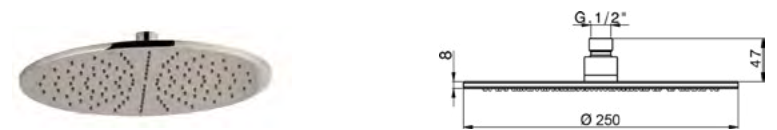

DS 016350
Soffione Doccia
Shower Head
Douche de Tête

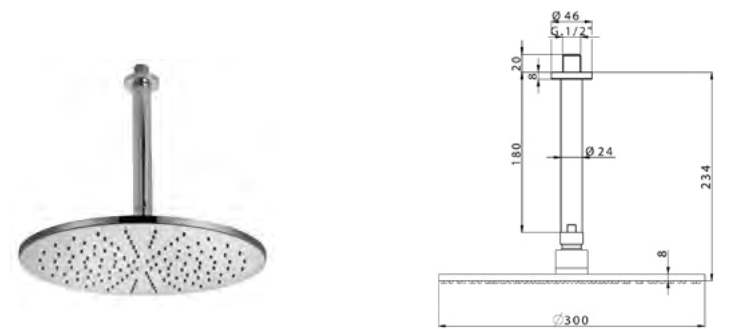

DS 013700
Braccio e Soffione Doccia
Shower Arm & Head
Bras et Tête de Douche



DS 015090
Soffione Laterale
Body Jet
Buse Murale



DS 013570
Soffione Doccia 2 Funzioni: Pioggia/Cascata
2-Function Shower Head: Rain/Waterfall
Douche de Tête 2 Fonctions: Pluie/Cascade

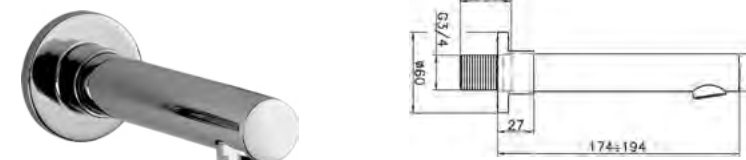

SM 000240
Bocca di Erogazione
Filler Spout
Bec Verseur

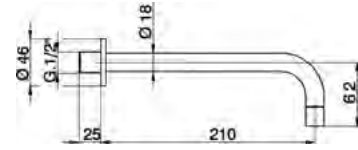

ZA 002250
Bocca di Erogazione
Filler Spout
Bec Verseur

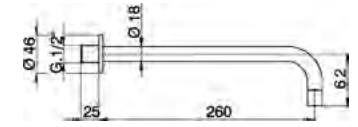

ZA 002251
Bocca di Erogazione
Filler Spout
Bec Verseur

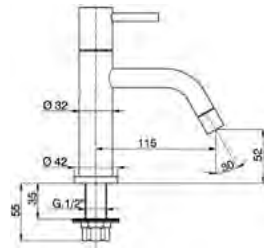

LN 000900
Rubinetto Lavamani
Pillar Tap
Robinet Lave Mains

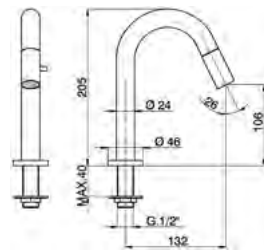

LM 000910
Rubinetto Lavamani
Pillar Tap
Robinet Lave Mains

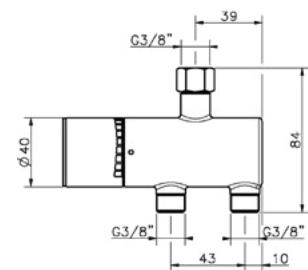

TX T83010
Termostatico Sottolavabo
Underbasin Thermo
Thermo Sous Lavabo

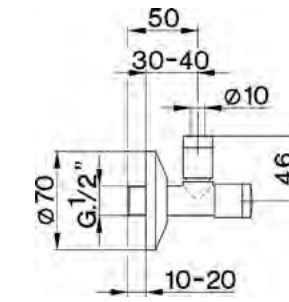

ZA 002900
Rubinetto Filtro di Alimentazione
Angle Valve
Robinet à Equerre

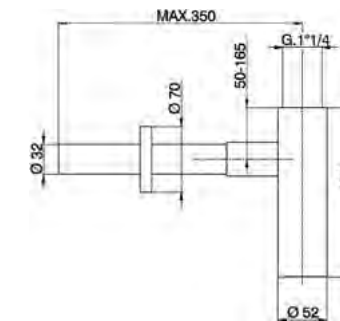

ZA 004070
Sifone
Siphon
Siphon



ZA 001620
Scarico Click-Clack
Click-Clack Waste
Vidage Click-Clack

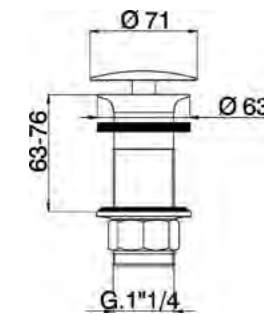

ZA 001611
Scarico Sempre Aperto
Open Flow Waste
Vidage Ouvert

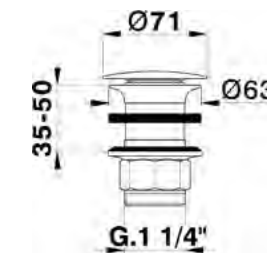

ZA 001610
Scarico Sempre Aperto
Open Flow Waste
Vidage Ouvert

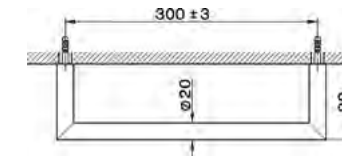

SY 090100
Porta Salviette
Towel Rail
Porte-Serviette

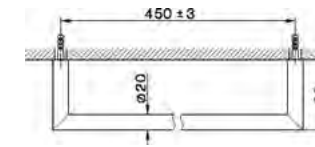

SY 090101
Porta Salviette
Towel Rail
Porte-Serviette

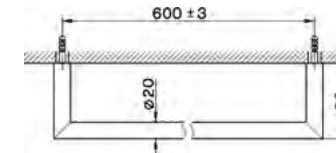

SY 090102
Porta Salviette
Towel Rail
Porte-Serviette

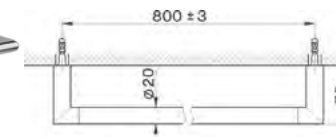

SY 090103
Porta Salviette
Towel Rail
Porte-Serviette

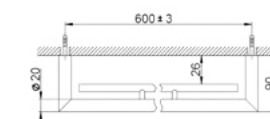
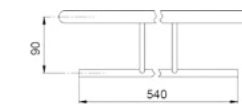
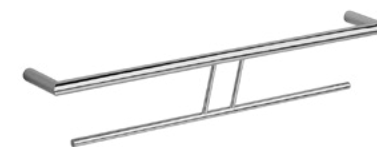

SY 090200
Porta Salviette
Towel Rail
Porte-Serviette

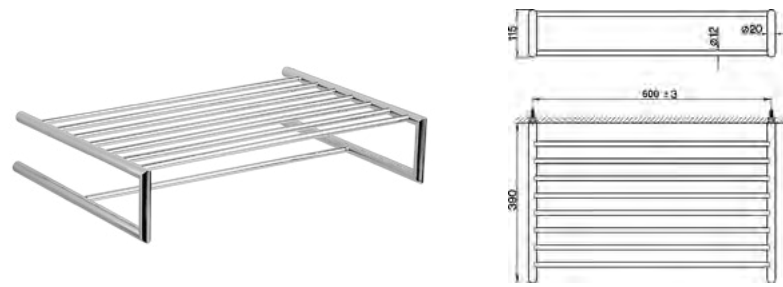

SY 090300
Porta Salviette
Towel Rail
Porte-Serviette



SY 090210
Porta Salviette
Towel Rail
Porte-Serviette



SY 090700
Appendino Multiplo
Multiple Hook
Porte-Peignoir



SY 090710
Appendino
Hook
Porte-Peignoir

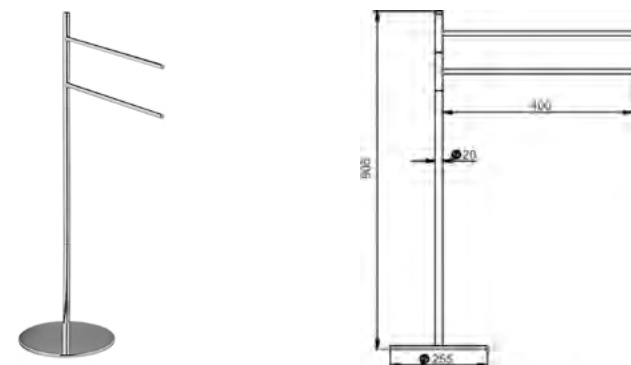

SY 090910
Porta Salviette
Free-Standing Towel Rail
Porte-Serviette

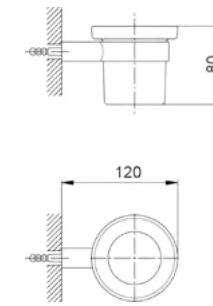

SY 090500
Porta Bicchieri
Toothbrush Holder
Porte-Verre

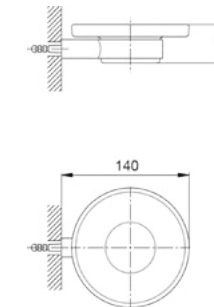

SY 090600
Porta Sapone
Soap Holder
Porte-Savon

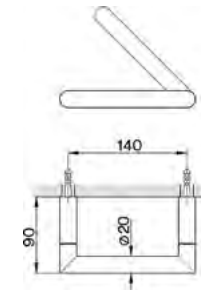

SY 090400
Porta Rotolo
Roll Holder
Porte-Papier

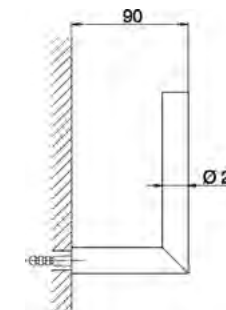

SY 090410
Porta Rotolo
Roll Holder
Porte-Papier

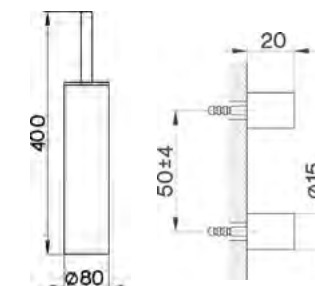

SY 090650
Porta Scopino
Brush Holder
Porte-Brosse

SY 090660
Kit Installazione a Muro
Wall Fixing Kit
Kit d'Installation Murale

METALLI CLASSICI | CLASSIC METALS

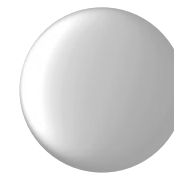

Chrome
2I



Polished Nickel
2B



Brushed Nickel
2F

METALLI SPECIALI PVD | PVD SPECIAL METALS



Black Titanium
2Q



Rose Gold
2P

COLORI | COLOURS

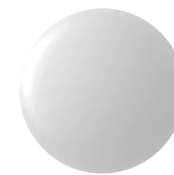

Snow White
4Q



Night Black
40

Art Direction Studio Rotella

CREDITS

Text and Editing
CISAL Atelier

Art Direction
Fabio Rotella

Graphic Design and Layout
Studio Rotella Milano

Photography
Dario De Sirianna
Marco Siracusano

Printing
Tipolitografia Testori

Thanks to
"Museo del Rubinetto e della sua Tecnologia"

Printed in Italy

cisal

cisal

cisal

Art Direction Studio Rotella



CISAL

28010 Alzo di Pella (NO) - Italia - Via Pietro Durio 160 - Tel. +39 0322 918111 - Fax +39 0322 969518
cisal@cisal.it - www.cisal.it