

cisal

*NUOVA LESS
Collection*

design by Cisol Atelier



cisal



cisal

FATTARON

«La bellezza del luogo ci illude, e a momenti ci fa credere che il tempo si sia fermato»

Orta mia. Mario Soldati 1960

“The beauty of this place deceives us, and at times makes us believe that time stands still”

Orta mia. Mario Soldati 1960



CHI SIAMO

CISAL rappresenta un esempio di industria italiana autonoma ed integrata, a ciclo di produzione completo, caratterizzato da soluzioni tecnologiche e gestionali innovative. Cisol è oggi uno dei protagonisti dell'innovazione nel settore, con grande sensibilità per l'efficiente uso delle risorse, in primis acqua ed energia, e costante attenzione allo sviluppo continuo di prodotti innovativi nel design, nei materiali, nel funzionamento e nelle prestazioni. Le Collezioni combinano sapientemente estetica, funzionalità e affidabilità, grazie alla collaborazione con designers internazionali quali Karim Rashid, Giampiero Peia, Fabio Rotella, the Collections masterfully combine aesthetics, functionality and reliability.

ABOUT US

Cisal is the outstanding example of an independent and fully integrated Italian manufacturer, performing the complete production cycle, characterised by innovative technology and management solutions.

Cisal is now one of the leading innovators in the industry and is very conscience about the efficient use of resources, water and energy, and focuses on the continuous development of innovative products with regard to design, materials, function and performance. Thanks to collaboration with international designers such as Karim Rashid, Giampiero Peia, Fabio Rotella, the Collections masterfully combine aesthetics, functionality and reliability.



1952

Fondata nel 1952 da Liborio Soldi e battezzata CISAL, la società ha attraversato tutte le stagioni dell'epopea della rubinetteria di cui il Cusio è protagonista fin dagli albori.

Founded in 1952 by Liborio Soldi and named CISAL, the company has gone through all the epic seasons of brassware industry where Cusio has been the protagonist since the beginning.



1980

Nel 1980 l'Arch. Raffaella Vecchi disegna la serie ARCANA, un prodotto icona classico e storico che apre nuovi orizzonti nei mercati esteri, che si sviluppano passando anche attraverso la creazione di una filiale in Germania nel 1991.

In 1980 the Architect Raffaella Vecchi, designed the ARCANA series, a classical and historical icon that opens up new horizons in foreign markets, which also led to the establishment of a daughter company in Germany in 1991.



1981

Dal lavoro di sviluppo interno coordinato da Daniele Sirini, nasce la prima cartuccia a dischi ceramici monocomando. Il nuovo BLITZ apre la gloriosa storia delle serie di miscelazione Cisol.

The first single handle ceramic disc cartridge was developed internally by Daniele Sirini and his team. The glorious history of Cisol mixer series begins with the new BLITZ series.



1999

Nel 1999, viene realizzato un nuovo stabilimento disegnato dall'Arch. Giampiero Peia e attrezzato con modernissimi impianti di cogenerazione, galvanica e magazzino elettronico. Qui si concentrano le tecnologie più avanzate del settore e si supporta una crescita continua nella progettazione del prodotto, nell'ingegnerizzazione del manufatto e del prodotto finito.

In 1999, a new factory building designed by the architect Giampiero Peia was built and equipped with modern cogeneration and plating plants along with an electronic warehouse. Here, using the most advanced technologies in the industry, product design and the engineering of the part and the finished product are in continuous development.



2009

Nel 2009 la famiglia Huber, proprietaria di Huber, leader nella fabbricazione di miscelatori termostatici, decide di fare una scelta strategica per il futuro, acquisendo Cisol per garantirle un asse di sviluppo tecnologico e industriale assolutamente vincente: combinare know-how, esperienza e capacità produttive per offrire al progettista e alla clientela una variegata e completa gamma di prodotti integrati a miscelazione termostatica, monocomando e tradizionale.

In 2009 the Huber family, owner of Huber, a leading manufacturer of thermostatic mixers, decided to make a strategic choice for the future, by acquiring Cisol and providing the company with an absolutely successful technological and industrial development format: to combine know-how, experience and production capacities in order to offer designers and customers a wide and complete range of single lever, traditional, and thermostatic brassware products.



2016

Nel 2016 l'Architetto Fabio Rotella entra a far parte del team dell'azienda e in qualità di art director ha ideato "CISALAtelier", centro creativo che, attraverso la ricerca e la sperimentazione, lavora su progetti di prodotti sempre più protagonisti, grazie ad un autentico appeal.

Architect Fabio Rotella joining the team in 2016 as the brand art director, he developed the "CISALAtelier" concept, a creative network which, through research and experimentation, will be protagonist on projects of key products thanks to their authentic appeal.



ECCELLENZA MADE IN ITALY

Cisal rappresenta un capitolo importante della storia della rubinetteria italiana. Una lunga tradizione di ingegno, mestiere e professionalità, declinata ed esaltata nel rispetto e nella considerazione per l'uomo ed il territorio: il Lago d'Orta, luogo in cui si concentra da generazioni il distretto della rubinetteria, retaggio di artigianalità e cultura del saper fare italiano.

MADE IN ITALY EXCELLENCE

Cisal represents an important chapter in the history of Italian brassware. A long tradition of ingenuity, skill and professionalism, identified and enhanced in respect and consideration for humans and the territory: Lake Orta, the area where taps have been made for generations, has a heritage of craftsmanship and a culture of Italian know-how.



cisal Atelier CONCEPT

L'acqua è l'elemento essenziale per l'essere umano e il suo controllo è importante sin dall'antichità. Il rubinetto, dispensatore del liquido vitale del quale facciamo un utilizzo quotidiano, è un prodotto funzionale e necessario ma può anche rappresentare un accessorio sofisticato, prezioso e sempre più protagonista nell'ambiente bagno. Cisol storicamente ha da sempre caratterizzato la sua vasta gamma di collezioni con un atteggiamento di ricerca formale riferito al design. Più recentemente, con l'integrazione delle competenze della famiglia Huber, Cisol si è ulteriormente elevata ad ancora più alti livelli di qualità e prestigio, affermandosi come un importante interprete del settore bagno e cucina a livello internazionale.

Nel 2016 l'Architetto Fabio Rotella entra a far parte del team dell'azienda e in qualità di art director ha ideato "CISALAtelier", centro creativo che, attraverso la ricerca e la sperimentazione, lavora su progetti di prodotti sempre più protagonisti, grazie ad un autentico appeal.

"In questi anni di grandi cambiamenti, in un contesto internazionale sempre più sofisticato e in continua evoluzione, Cisol, nella sua nuova visione strategica, intende sviluppare ed elevare la propria immagine rendendola unica e riconoscibile, e aumentare la percezione dei suoi prodotti e delle sue innovazioni sullo scenario globale. Nuovi materiali, nuove finiture, nuovi dettagli e nuove tecnologie per controllare e preservare l'acqua. Cisol si presenta come un'azienda Italiana di tradizione e all'avanguardia, proiettata verso il futuro e sempre più attenta alle attese di designers e utilizzatori e alla salvaguardia dell'elemento essenziale per il Pianeta: l'acqua."

Fabio Rotella

Water is the essential element for the human being - and controlling it has been important since ancient times.

The tap, dispenser of this vital liquid of which we use daily, is a functional and necessary product, but it can also be a sophisticated, precious accessory as well that plays an increasingly important role in the bathroom environment. Since its origin, Cisol's wide range of collections have always been characterized by formal research related to design. Recently, with the integration of the expertise of the Huber family, Cisol has elevated its already high levels of quality and prestige even further, establishing itself internationally as a major interpreter of the bathroom and kitchen industry.

Architect Fabio Rotella joining the team in 2016 as the brand art director, he developed the "CISALAtelier" concept, a creative network which, through research and experimentation, will be used on projects of key products thanks to their authentic appeal.

"During these years of great change, in an international context that is becoming more sophisticated and is constantly evolving, Cisol, with its new strategic vision, aims to develop and enhance its image, making it unique and recognizable, and to globally increase the perception of its products and innovations. New materials, new finishes, new details and new technologies to control and preserve water. Cisol is a cutting-edge, future-oriented Italian company that is rich in tradition and is increasingly aware of the expectations of designers and users, and the preservation of the essential element of our planet: water."

Fabio Rotella



WATER CREATIVITY



NUOVA LESS Collection

design by Cital Atelier

Essenza,
perfezione e
pulizia formale.

*Essence,
perfection and
clean lines.*

NUOVA LESS



18

LN 51
Monocomando Lavabo
Basin Mixer



19



LN 354
Monocomando Lavabo
Basin Mixer

NUOVA LESS



22

LN 551 6
Monocomando Lavabo
Basin Mixer



23

NUOVA LESS



LN 551 0
Monocomando Lavabo
Basin Mixer



24

LN 47
Monocomando Lavabo
Basin Mixer



LN 1451
Monocomando Lavabo Free-Standing
Free-Standing Basin Mixer

25



LN 106
Batteria Lavabo
Basin Set



LN 1351
Batteria Lavabo
Basin Set

NUOVA LESS



28

LN 1420
Completo Monocomando Vasca Free-Standing
Free-Standing Bath/S. Mixer Set



29



30

LN D2301
Completo Termostatico Vasca
Thermo Bath/S. Set



LN T3901
Completo Termostatico Vasca Freestanding
Free-Standing Bath/S. Thermo Set

31



NUOVA LESS



34

LN C7801
CombiDoccia Termostatico
Thermo CombiShower



LN 403
CombiDoccia Monocomando
CombiShower Mixer

35

NUOVA LESS



36

LN 1V20
Termostatico 2 Funzioni
2-Function Thermo



37

NUOVA LESS



38



LN 300
Monocomando Doccia
Shower Mixer



LN 210
Monocomando 2 Uscite
2-Outlet Mixer



DS 18813
Completo Doccia con Presa d'Acqua
Shower Set on Wall Elbow



DS 1072
Completo Doccia Saliscendi
Slide Rail Shower Set

39

NUOVA LESS



DS 1370
Braccio e Soffione Doccia
Shower Arm & Head

DS 18813
Completo Doccia con Presa d'Acqua
Shower Set on Wall Elbow

LN 331
Rubinetto
Stopvalve

LN 720
Termostatico 3/4"
3/4" Thermo



LN C7801
CombiDoccia Termostatico
Thermo CombiShower

NUOVA LESS



SY 9010 0 - SY 9010 1 - SY 9010 2
Porta Salviette
Towel Rail



SY 9091
Porta Salviette
Free-Standing Towel Rail



SY 9065
Porta Scopino
Brush Holder



SY 9070
Appendino Multiplo
Multiple Hook



Prodotti e Accessori
Products and Accessories
Produits et Accessoires

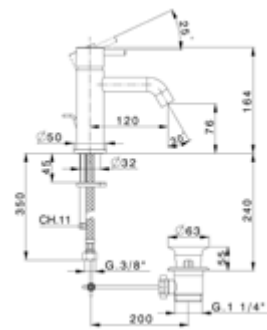

LN 000510
Monocomando Lavabo
Basin Mixer
Mitigeur Lavabo

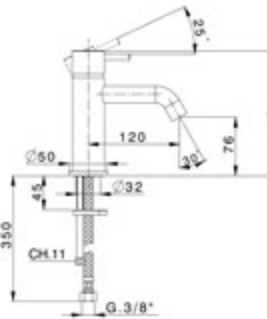

LN 000540
Monocomando Lavabo
Basin Mixer
Mitigeur Lavabo

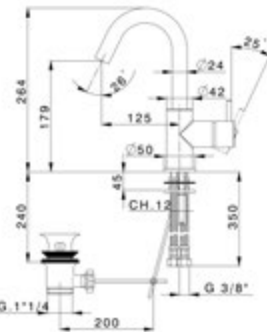

LN 000475
Monocomando Lavabo
Basin Mixer
Mitigeur Lavabo

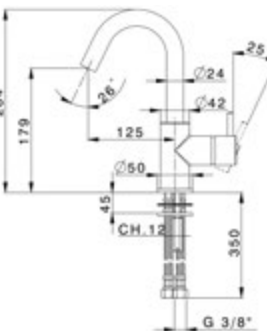
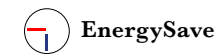

LN 000485
Monocomando Lavabo
Basin Mixer
Mitigeur Lavabo

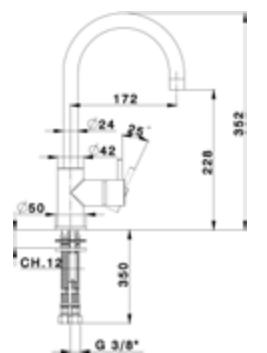
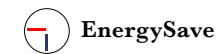

LN 000535
Monocomando Lavabo
Basin Mixer
Mitigeur Lavabo

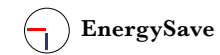

LN 003540
Monocomando Lavabo
Basin Mixer
Mitigeur Lavabo

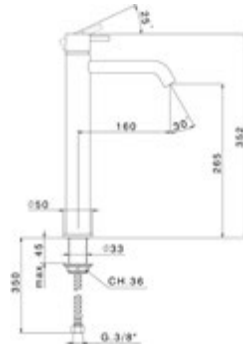

LN 004540
Monocomando Lavabo
Basin Mixer
Mitigeur Lavabo

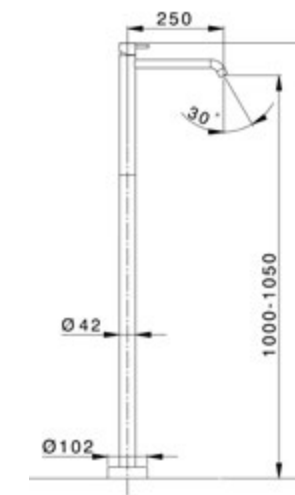

LN 014510
Parte Esterna Monocomando Lavabo
Free-Standing
Free-Standing Basin Mixer
Exposed Part
Partie Apparente Mitigeur Lavabo
Free-Standing

Vedi/See/Voir **ZA 004510**

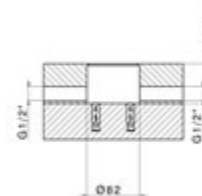

ZA 004510
Parte Incasso Monocomando
Free-Standing
Free-Standing Mixer Concealed Part
Partie Encastrée Mitigeur
Free-Standing

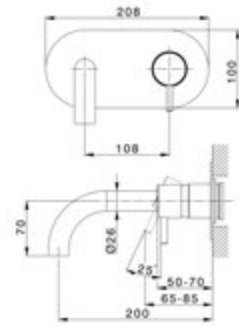

LN 005510
 Parte Esterna Monocomando Lavabo
 Basin Mixer Exposed Part
 Partie Apparente Mitigeur Lavabo

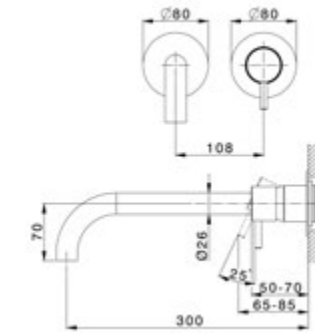

LN 005518
 Parte Esterna Monocomando Lavabo
 Basin Mixer Exposed Part
 Partie Apparente Mitigeur Lavabo

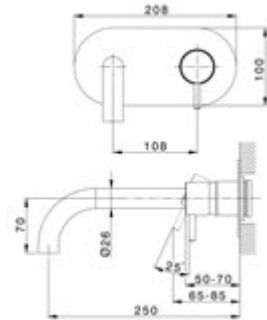

LN 005511
 Parte Esterna Monocomando Lavabo
 Basin Mixer Exposed Part
 Partie Apparente Mitigeur Lavabo

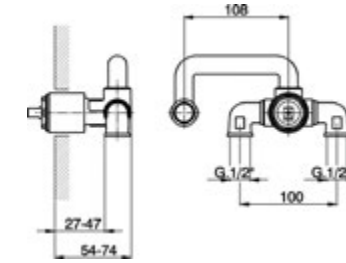

ZA 025510
 Parte Incasso Monocomando Lavabo
 Basin Mixer Concealed Part
 Partie Encastrée Mitigeur Lavabo

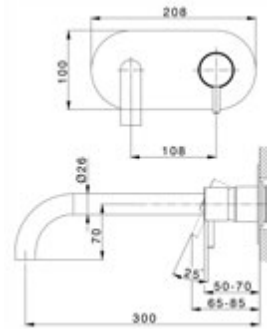

LN 005512
 Parte Esterna Monocomando Lavabo
 Basin Mixer Exposed Part
 Partie Apparente Mitigeur Lavabo

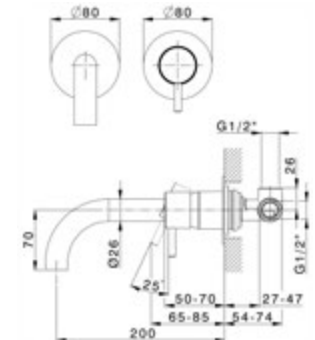

LN 002470
 Completo Monocomando Lavabo
 Parte Incasso + Parte Esterna
 Basin Mixer Set
 Concealed Part + Exposed Part
 Ensemble Mitigeur Lavabo
 Partie Encastrée + Partie Apparente

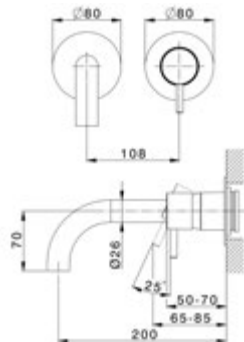

LN 005516
 Parte Esterna Monocomando Lavabo
 Basin Mixer Exposed Part
 Partie Apparente Mitigeur Lavabo

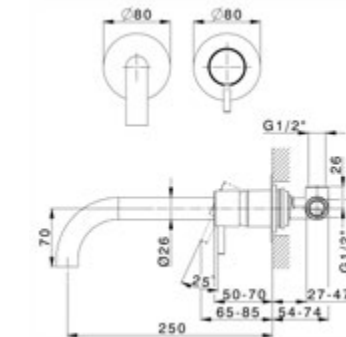

LN 002471
 Completo Monocomando Lavabo
 Parte Incasso + Parte Esterna
 Basin Mixer Set
 Concealed Part + Exposed Part
 Ensemble Mitigeur Lavabo
 Partie Encastrée + Partie Apparente

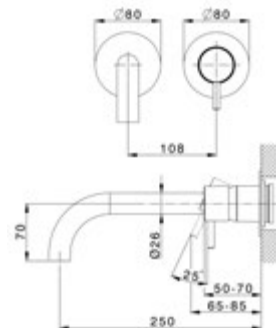

LN 005517
 Parte Esterna Monocomando Lavabo
 Basin Mixer Exposed Part
 Partie Apparente Mitigeur Lavabo

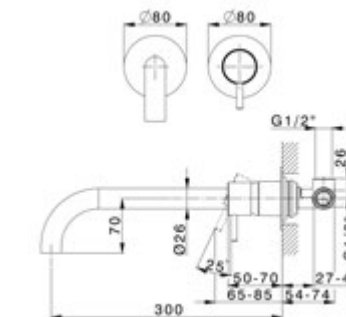

LN 002472
 Completo Monocomando Lavabo
 Parte Incasso + Parte Esterna
 Basin Mixer Set
 Concealed Part + Exposed Part
 Ensemble Mitigeur Lavabo
 Partie Encastrée + Partie Apparente

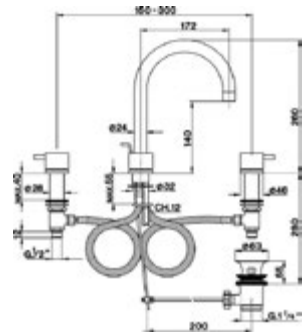

LN 001060
Batteria Lavabo
Basin Set
Lavabo 3 Trous

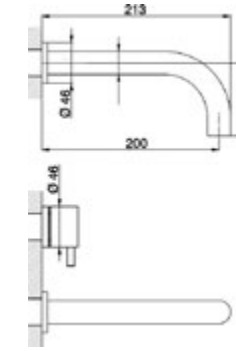

LN 013510
Parte Esterna Batteria Lavabo
Basin Set Exposed Part
Partie Apparente Lavabo Mural

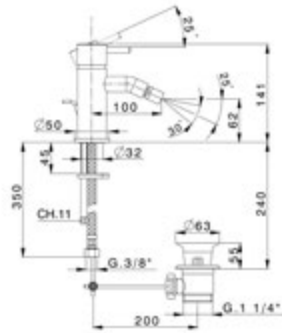

LN 000550
Monocomando Bidet
Bidet Mixer
Mitigeur Bidet

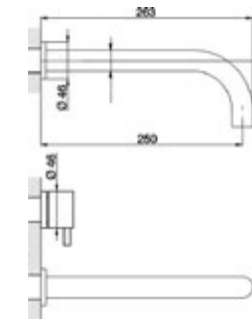

LN 013511
Parte Esterna Batteria Lavabo
Basin Set Exposed Part
Partie Apparente Lavabo Mural

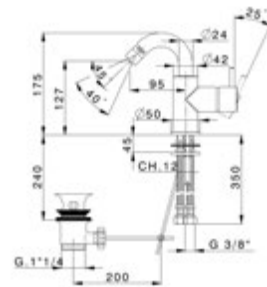

LN 002555
Monocomando Bidet
Bidet Mixer
Mitigeur Bidet

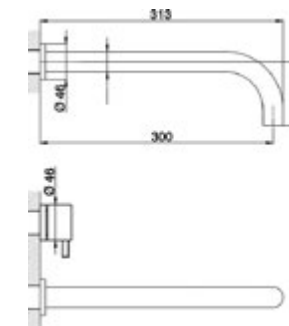
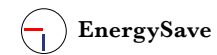

LN 013512
Parte Esterna Batteria Lavabo
Basin Set Exposed Part
Partie Apparente Lavabo Mural

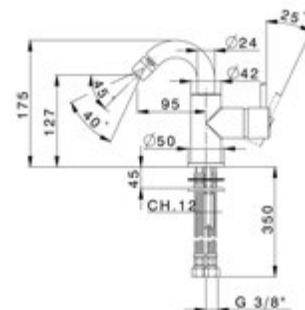

LN 002565
Monocomando Bidet
Bidet Mixer
Mitigeur Bidet

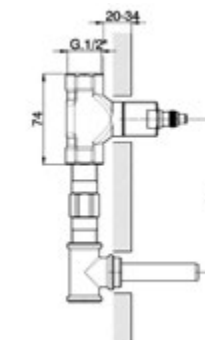
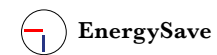

ZA 003500
Parte Incasso Batteria Lavabo
Basin Set Concealed Part
Partie Encastrée Lavabo Mural

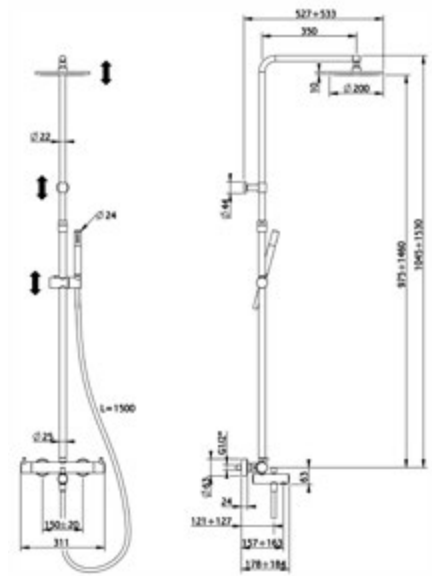

LN C8501D
CombiVasca Termostatico
Thermo CombiBath
CombiBain Thermo

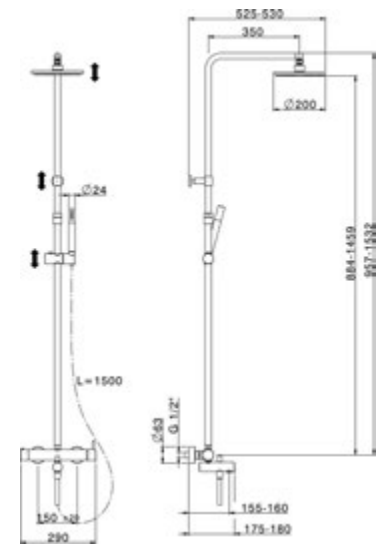

LN 004160
CombiVasca Monocomando
CombiBath Mixer
CombiBain Mitigeur

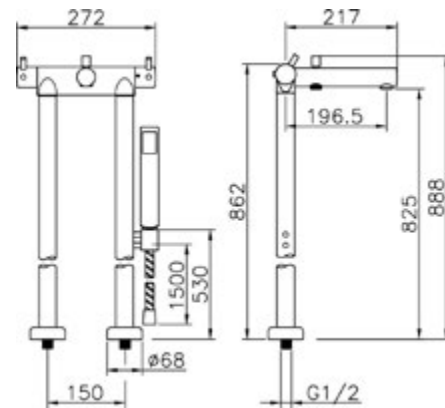

LN T39010
Completo Termostatico Vasca Free-Standing
Free-Standing Bath/S. Thermo Set
Ensemble Thermo Bain/D. Free-Standing

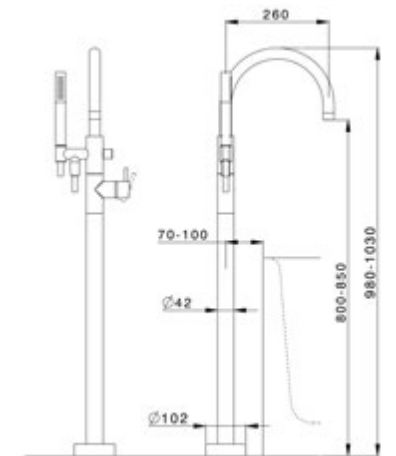

LN 014200
Parte Esterna Monocomando Vasca Free-Standing
Free-Standing Bath/S. Mixer Exposed Part
Partie Apparente Mitigeur Bain/D. Free-Standing

Vedi / See / Voir **ZA 004510**

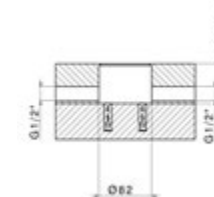

ZA 004510
Parte Incasso Monocomando
Free-Standing
Free-Standing Mixer Concealed Part
Partie Encastrée Mitigeur
Free-Standing

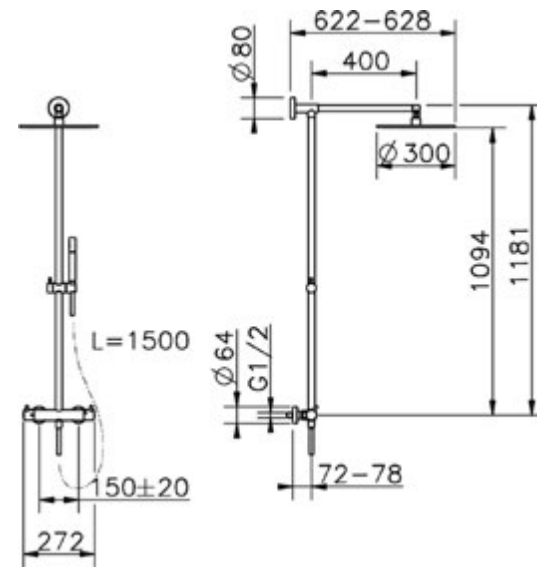

LN C7801N
 CombiDoccia Termostatico
 Thermo CombiShower
 CombiDouche Thermo

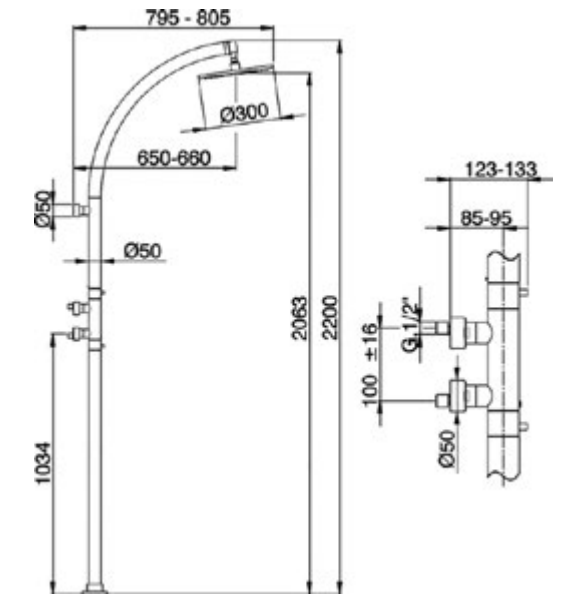

LN C90010
 Colonna Doccia Termostatica
 Thermo Shower Column
 Colonne de Douche Thermo

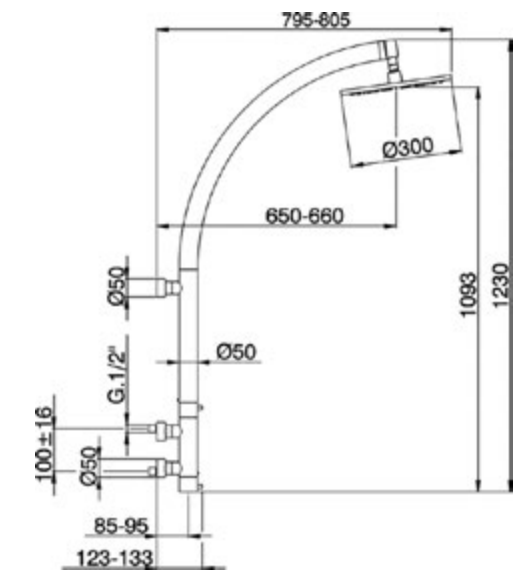

LN C91010
 Colonna Doccia Termostatica
 Thermo Shower Column
 Colonne de Douche Thermo

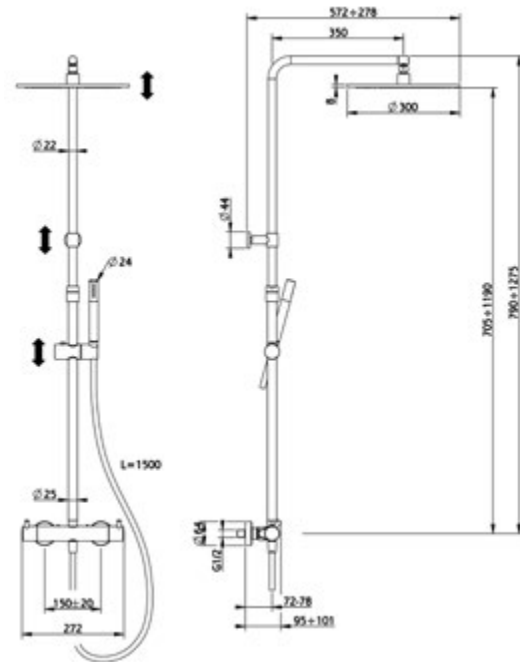

LN C8401D
CombiDoccia Termostatico
Thermo CombiShower
CombiDouche Thermo

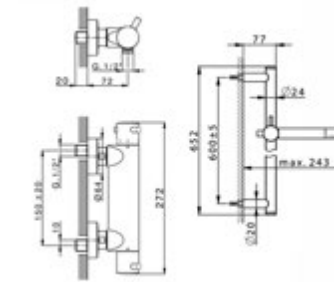

LN S01010
Completo Termostatico Doccia
Thermo Shower Set
Ensemble Thermo Douche

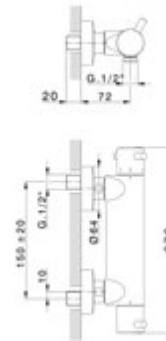

LN T01010
Termostatico Doccia
Shower Thermo
Thermo Douche

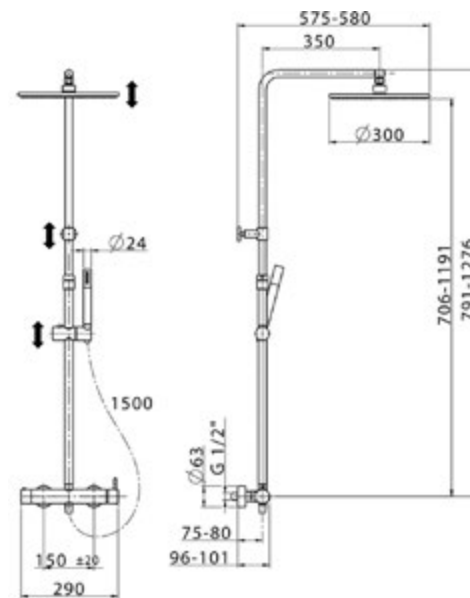

LN 004030
CombiDoccia Monocomando
CombiShower Mixer
CombiDouche Mitigeur

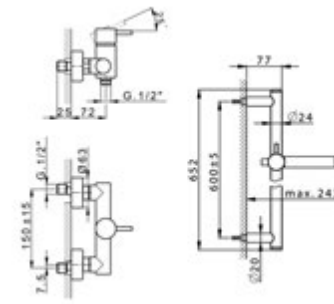

LN 000460
Completo Monocomando Doccia
Shower Mixer Set
Ensemble Mitigeur Douche

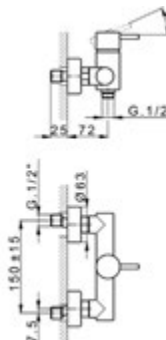

LN 000440
Monocomando Doccia
Shower Mixer
Mitigeur Douche

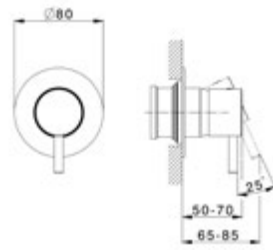

LN 003000
 Parte Esterna Monocomando Doccia
 Shower Mixer Exposed Part
 Partie Décor Mitigeur Douche

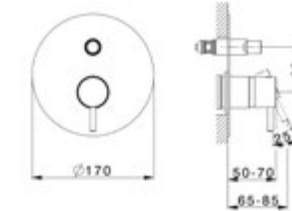

LN 002100
 Parte Esterna Monocomando 2 Uscite
 2-Outlet Mixer Exposed Part
 Partie Décor Mitigeur 2 Sorties

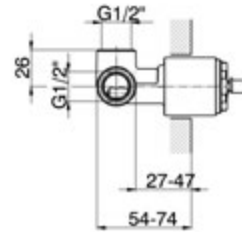

ZA 005300
 Parte Incasso Monocomando Doccia
 Shower Mixer Concealed Part
 Partie Encastrée Mitigeur Douche

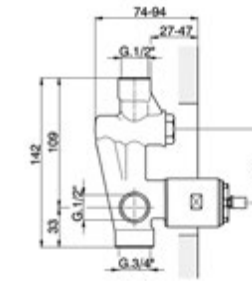

ZA 005210
 Parte Incasso Monocomando 2 Uscite
 2-Outlet Mixer Concealed Part
 Partie Encastrée Mitigeur 2 Sorties

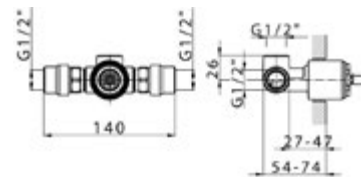

ZA 005301
 Parte Incasso Monocomando Doccia
 con Silenziatori
 Shower Mixer Concealed Part
 with Noise Reducers
 Partie Encastrée Mitigeur Douche
 avec Silencieux

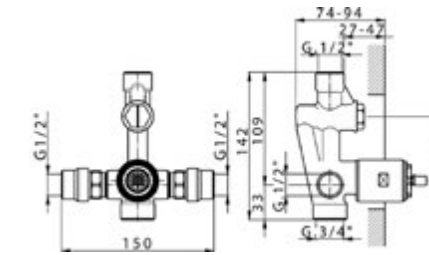

ZA 005211
 Parte Incasso Monocomando 2 Uscite
 con Silenziatori
 2-Outlet Mixer Concealed Part
 with Noise Reducers
 Partie Encastrée Mitigeur 2 Sorties
 avec Silencieux

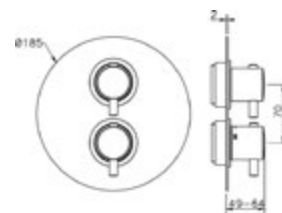

LN 007300
 Parte Esterna Termostatico Doccia
 Thermo Shower Exposed Part
 Partie Décor Thermo Douche

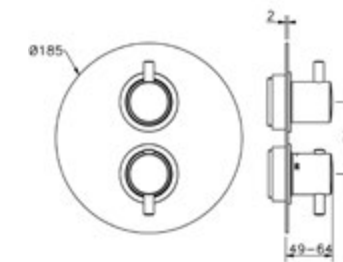

LN 018100
 Parte Esterna Termostatico 2 Uscite
 2-Outlet Thermo Exposed Part
 Partie Décor Thermo 2 Sorties

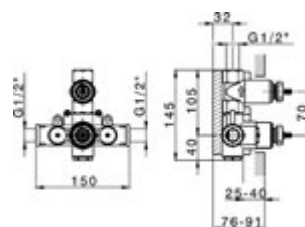

ZA 007301
 Parte Incasso Termostatico Doccia
 Thermo Shower Concealed Part
 Partie Encastrée Thermo Douche

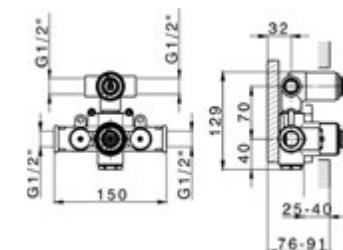

ZA 018101
 Parte Incasso Termostatico 2 Uscite
 2-Outlet Thermo Concealed Part
 Partie Encastrée Thermo 2 Sorties

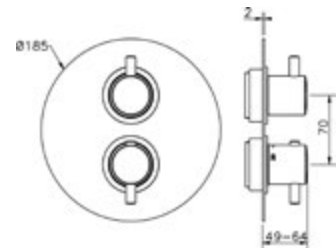

LN 018200
 Parte Esterna Termostatico 3 Uscite
 3-Outlet Thermo Exposed Part
 Partie Décor Thermo 3 Sorties

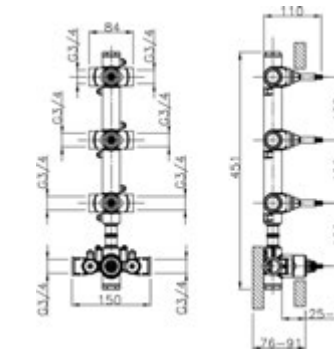

ZA 01V300
 Parte Incasso Termostatico 3 Funzioni
 3-Function Thermo Concealed Part
 Partie Encastrée Thermo 3 Fonctions

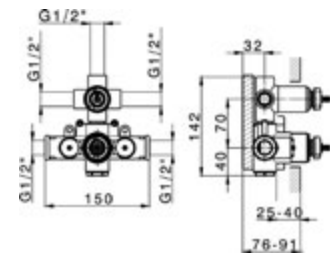

ZA 018201
 Parte Incasso Termostatico 3 Uscite
 3-Outlet Thermo Concealed Part
 Partie Encastrée Thermo 3 Sorties

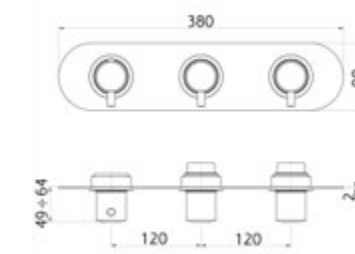

LN 01R200
 Parte Esterna Termostatico 2 Funzioni
 2-Function Thermo Exposed Part
 Partie Décor Thermo 2 Fonctions

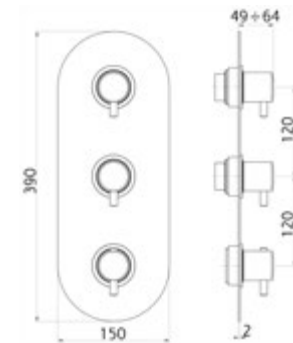

LN 01V200
 Parte Esterna Termostatico 2 Funzioni
 2-Function Thermo Exposed Part
 Partie Décor Thermo 2 Fonctions

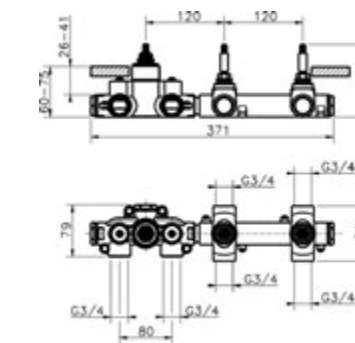

ZA 01R200
 Parte Incasso Termostatico 2 Funzioni
 2-Function Thermo Concealed Part
 Partie Encastrée Thermo 2 Fonctions

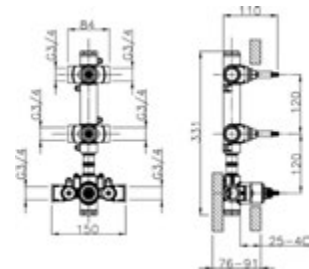

ZA 01V200
 Parte Incasso Termostatico 2 Funzioni
 2-Function Thermo Concealed Part
 Partie Encastrée Thermo 2 Fonctions

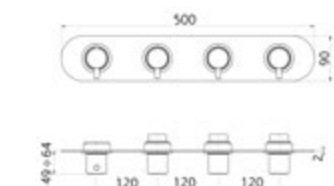

LN 01R300
 Parte Esterna Termostatico 3 Funzioni
 3-Function Thermo Exposed Part
 Partie Décor Thermo 3 Fonctions

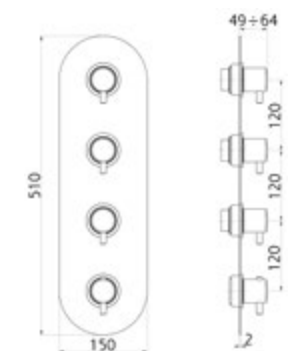

LN 01V300
 Parte Esterna Termostatico 3 Funzioni
 3-Function Thermo Exposed Part
 Partie Décor Thermo 3 Fonctions

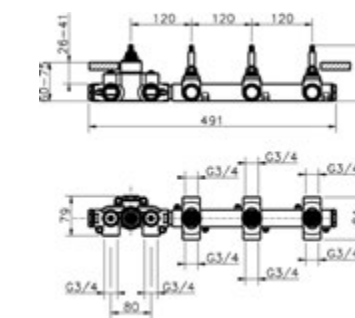

ZA 01R300
 Parte Incasso Termostatico 3 Funzioni
 3-Function Thermo Concealed Part
 Partie Encastrée Thermo 3 Fonctions

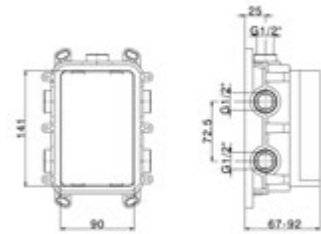

ZA 00B030
 Parte Incasso ONE Box
 ONE Box Concealed Part
 Partie Encastrée ONE Box

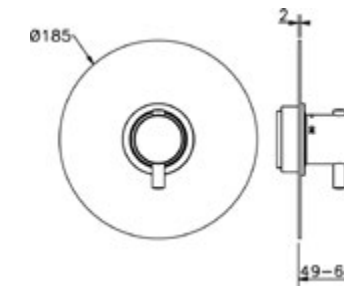

LN 007200
 Parte Esterna Termostatico 3/4"
 3/4" Thermo Exposed Part
 Partie Décor Thermo 3/4"

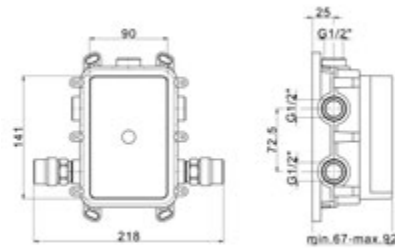

ZA 00B031
 Parte Incasso ONE Box con Silenziatori
 ONE Box Concealed Part with Noise Reducers
 Partie Encastrée ONE Box avec Silencieux

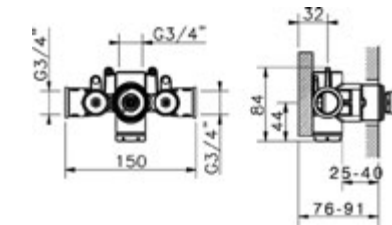

ZA 007221
 Parte Incasso Termostatico 3/4"
 3/4" Thermo Concealed Part
 Partie Encastrée Thermo 3/4"

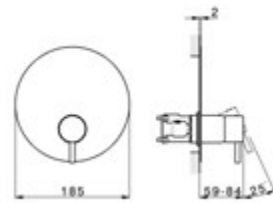

LN 0BM010
 Parte Esterna Monocomando 1 Uscita
 1 Outlet Mixer Exposed Part
 Partie Décor Mitigeur 1 Sortie

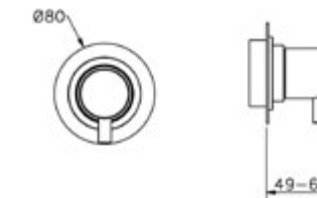

LN 003310
 Parte Esterna Rubinetto
 Stopvalve Exposed Part
 Partie Décor Robinet

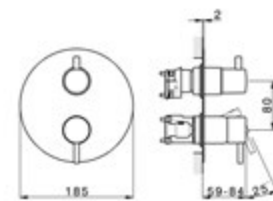

LN 0BM030
 Parte Esterna Monocomando 2/3 Uscite
 2/3 Outlet Mixer Exposed Part
 Partie Décor Mitigeur 2/3 Sorties

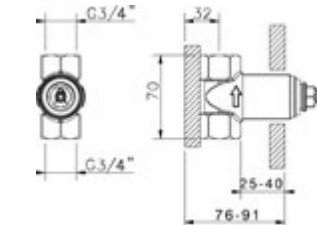

ZA 003330
 Parte Incasso Rubinetto 3/4"
 3/4" Stopvalve Concealed Part
 Partie Encastrée Robinet 3/4"

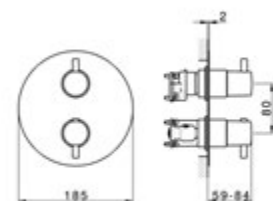

LN 0BT030
 Parte Esterna Termostatico 1/2/3 Uscite
 1/2/3 Outlet Thermo Exposed Part
 Partie Décor Thermo 1/2/3 Sorties

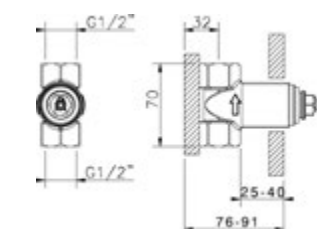

ZA 003340
 Parte Incasso Rubinetto 1/2"
 1/2" Stopvalve Concealed Part
 Partie Encastrée Robinet 1/2"

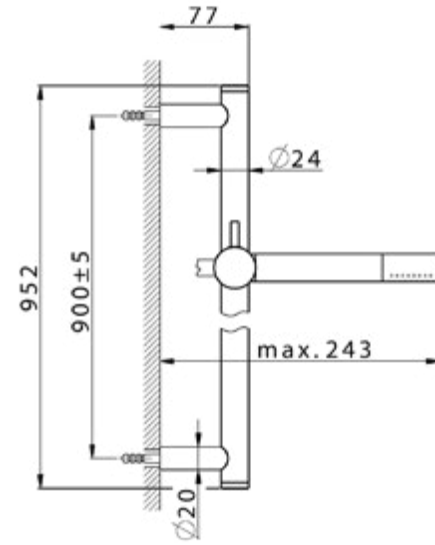

DS 010720
Completo Doccia Saliscendi 90 cm
90 cm Slide Rail Shower Set
Ensemble Barre de Douche 90 cm

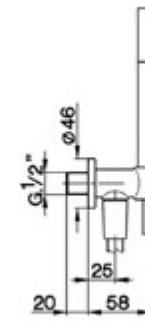

DS 018813
Completo Doccia con Presa d'Acqua
Shower Set on Wall Elbow
Ensemble de Douche sur Coude Mural

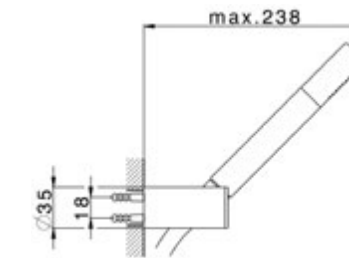

DS 018360
Completo Doccia
Shower Set
Ensemble de Douche

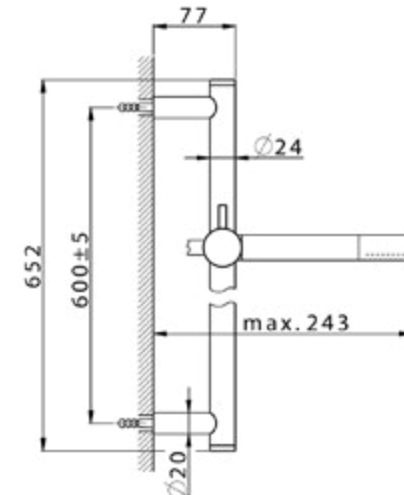

DS 010721
Completo Doccia Saliscendi 60 cm
60 cm Slide Rail Shower Set
Ensemble Barre de Douche 60 cm

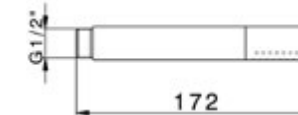

DS 014090
Doccetta
Hand Shower
Douchette à Main

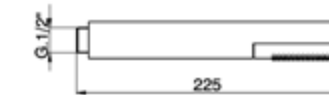

DS 014230
Doccetta
Hand Shower
Douchette à Main

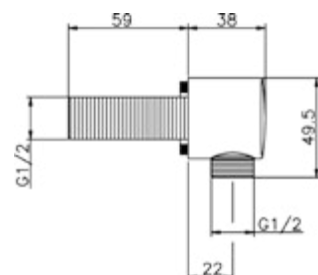

DS 017320
Presa d'Acqua
Wall Elbow
Coude Mural

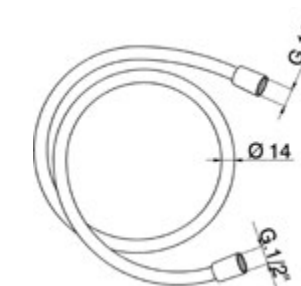

ZA 009040
Flessibile Doccia SUPREME
SUPREME Shower Hose
Flexible de Douche SUPREME



DS 013610
Braccio e Soffione Doccia
Shower Arm & Head
Bras et Tête de Douche



DS 013620
Braccio e Soffione Doccia
Shower Arm & Head
Bras et Tête de Douche



DS 013630
Braccio e Soffione Doccia
Shower Arm & Head
Bras et Tête de Douche



DS 013700
Braccio e Soffione Doccia
Shower Arm & Head
Bras et Tête de Douche

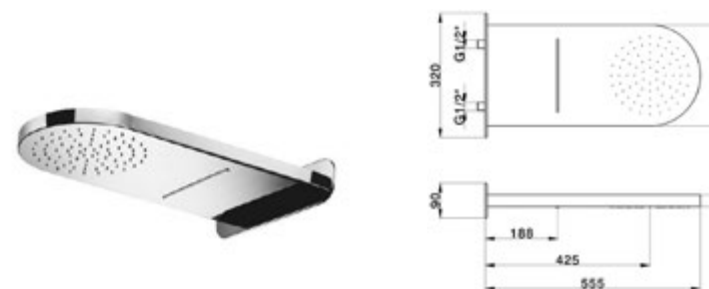

DS 013570
Soffione Doccia 2 Funzioni: Pioggia/Cascata
2-Function Shower Head: Rain/Waterfall
Douche de Tête 2 Fonctions: Pluie/Cascade

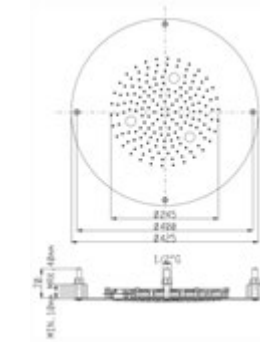

ZS 027180
Soffione Doccia a Controsoffitto Cromoterapia,
Funzione Pioggia, 3 Led RGB
Ceiling Mounted Shower Head,
Rain Function, 3 Led RGB
Ciel de Pluie Encastré, Fonction Pluie,
3 Led RGB

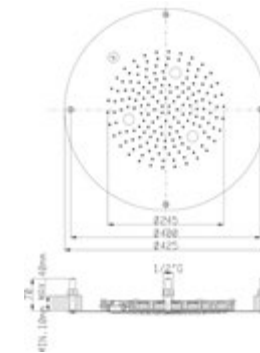

ZS 027170
Soffione Doccia a Controsoffitto Cromoterapia,
Funzione Pioggia, 3 Led RGB - con Pulsantiera
Ceiling Mounted Shower Head, Rain Function,
3 Led RGB - with Remote Control
Ciel de Pluie Encastré, Fonction Pluie,
3 Led RGB - avec Commande

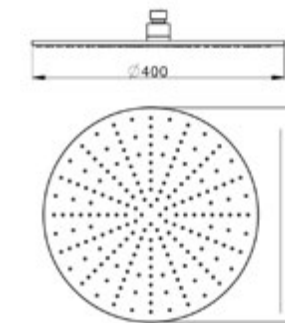

DS 016370
Soffione Doccia
Shower Head
Douche de Tête

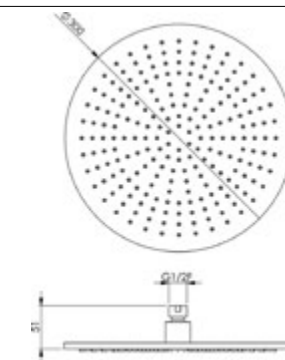

DS 016330
Soffione Doccia
Shower Head
Douche de Tête

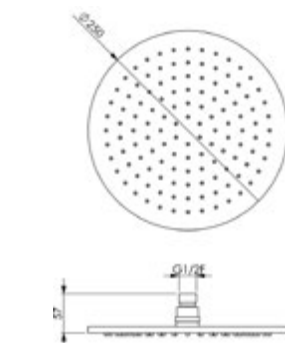

DS 016350
Soffione Doccia
Shower Head
Douche de Tête

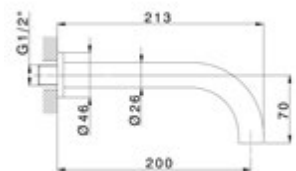

LN 000240
Bocca di Erogazione
Filler Spout
Bec Verseur

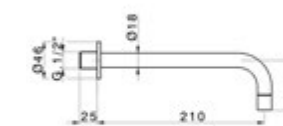

ZA 002250
Bocca di Erogazione
Filler Spout
Bec Verseur

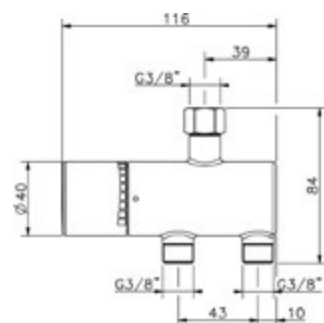

TX T83010
Termostatico Sottolavabo
Underbasin Thermo
Thermo Sous Lavabo

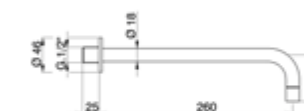

ZA 002251
Bocca di Erogazione
Filler Spout
Bec Verseur

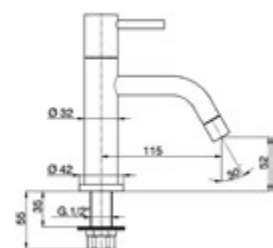

LN 000900
Rubinetto Lavamani
Pillar Tap
Robinet Lave Main

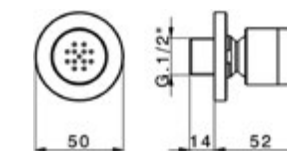

DS 015090
Soffione Laterale
Body Jet
Buse Murale

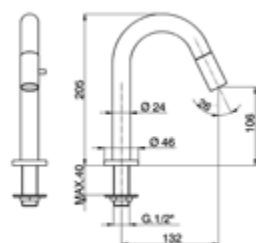

LM 000910
Rubinetto Lavamani
Pillar Tap
Robinet Lave Main

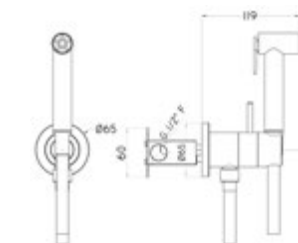

CY 007945
Set Miscelatore Doccetta Igienica
Bidet Hand Shower Mixer Set
Kit Mitigeur Douche d'Hygiène

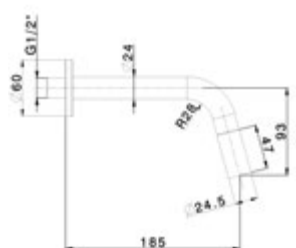

LM 001420
Rubinetto Lavamani
Wall Mounted Tap
Robinet Lave Main

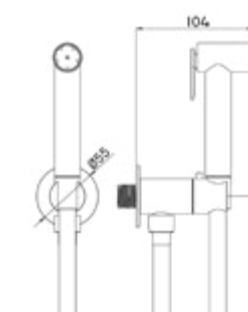

CY 007920
Set Doccetta Idroscopino
Toilet-Jet Hand Shower Set
Kit Douche pour Cuvette

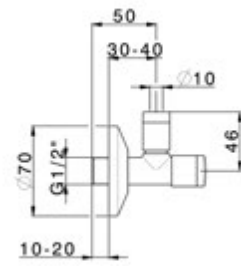

ZA 002900
 Rubinetto Filtro di Alimentazione
 Angle Valve
 Robinet à Equerre

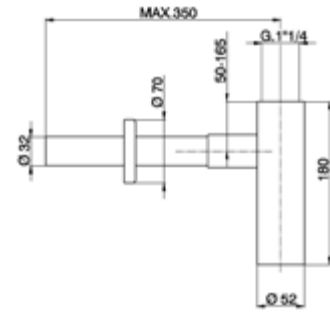

ZA 004070
 Sifone
 Siphon
 Siphon

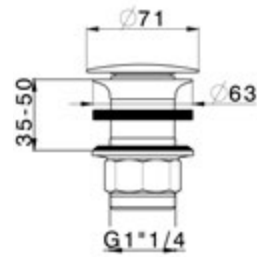

ZA 001610
 Scarico Sempre Aperto
 Open Flow Waste
 Vidage Ouvert

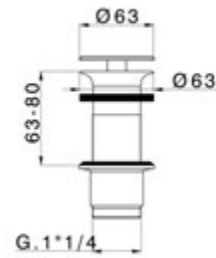

ZA 001613
 Scarico Sempre Aperto
 Open Flow Waste
 Vidage Ouvert

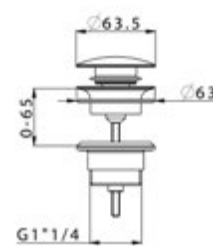

ZA 001780
 Scarico Click-Clack
 Click-Clack Waste
 Vidage Click-Clack





SY 090100
Porta Salviette
Towel Rail
Porte-Serviette

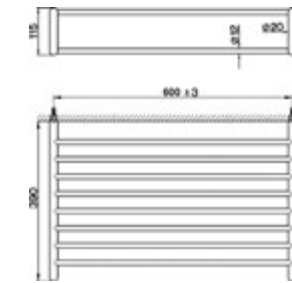

SY 090300
Porta Salviette
Towel Rail
Porte-Serviette

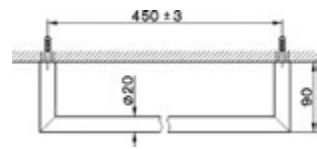

SY 090101
Porta Salviette
Towel Rail
Porte-Serviette

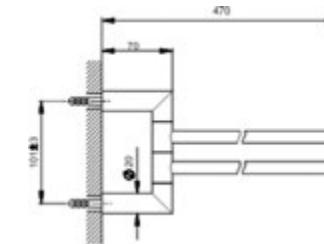

SY 090210
Porta Salviette
Towel Rail
Porte-Serviette

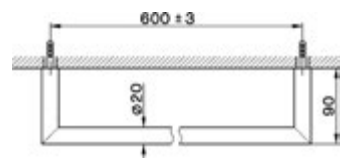

SY 090102
Porta Salviette
Towel Rail
Porte-Serviette



SY 090700
Appendino Multiplo
Multiple Hook
Porte-Peignoir Multiple

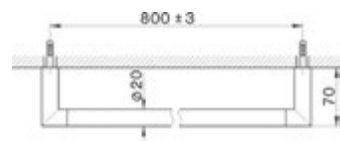

SY 090103
Porta Salviette
Towel Rail
Porte-Serviette

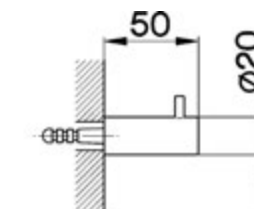

SY 090710
Appendino
Robe Hook
Porte-Peignoir

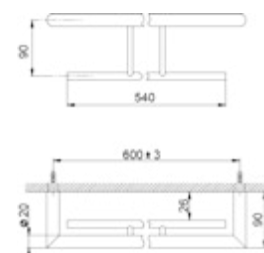
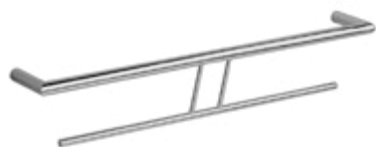

SY 090200
Porta Salviette
Towel Rail
Porte-Serviette

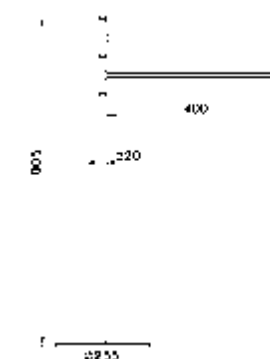

SY 090910
Porta Salviette
Free-Standing Towel Rail
Porte-Serviette

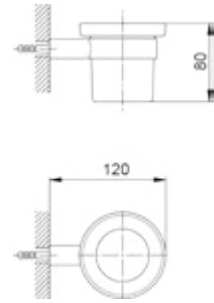

SY 090500
Porta Bicchiere
Toothbrush Holder
Porte-Verre

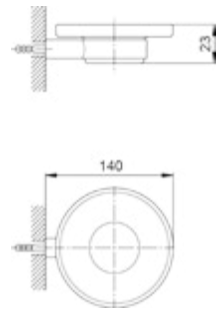

SY 090600
Porta Sapone
Soap Holder
Porte-Savon

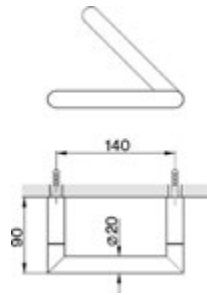

SY 090400
Porta Rotolo
Roll Holder
Porte-Papier

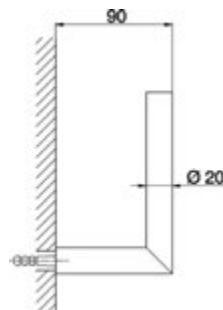

SY 090410
Porta Rotolo
Roll Holder
Porte-Papier

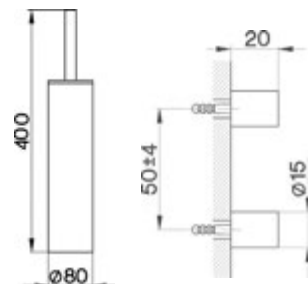

SY 090650
Porta Scopino
Brush Holder
Porte-Brosse

SY 090660
Kit Installazione a Muro
Wall Fixing Kit
Kit d'Installation Murale

METALLI CLASSICI | CLASSIC METALS



Chrome
21



Brushed Nickel
2F

COLORI | COLOURS



Snow White
4Q



Night Black
40

CREDITS

Text and Editing
CISAL Atelier

Art Direction
Fabio Rotella

Graphic Design and Layout
Studio Rotella Milano

Photography
Dario De Sirianna
Marco Siracusano

Printing
Tipolitografia Testori

Thanks to
“Museo del Rubinetto e della sua Tecnologia”

Printed in Italy

cisal

cisal

cisal



CISAL
28010 Alzo di Pella (NO) - Italia - Via Pietro Durio 160 - Tel. +39 0322 918111 - Fax +39 0322 969518
cisal@cisal.it - www.cisal.it